

REVISIONS			
REV.	DESCRIPTION	DATE	APPROVED
2	ADD .5MM X 12mm SLIT	12/27/2000	SH
3	DEL HORIZ SLIT, WAS FLASH 100	1/10/2011	SH

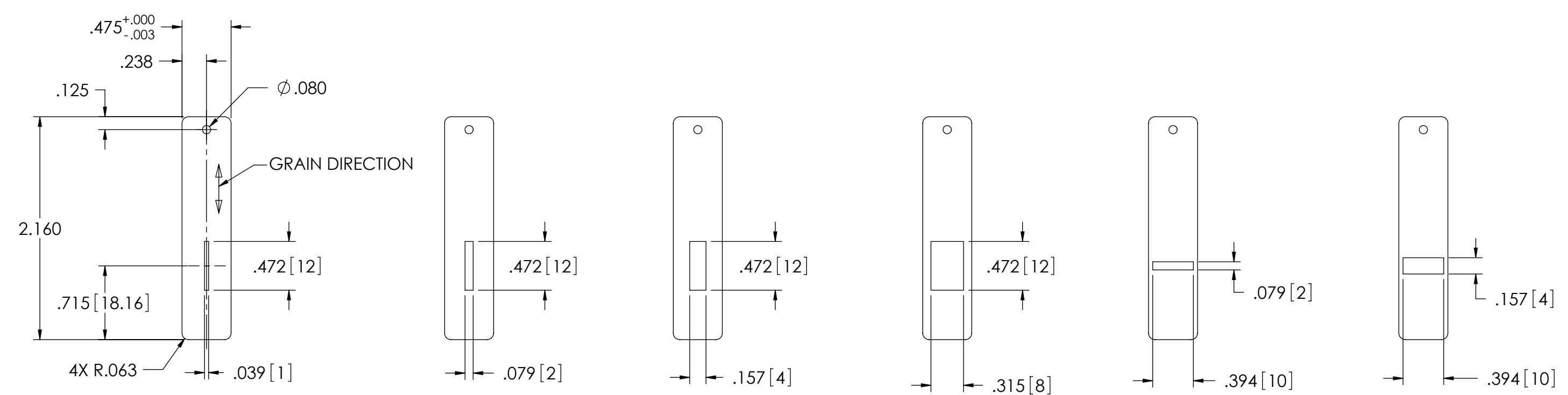

NOTE 2

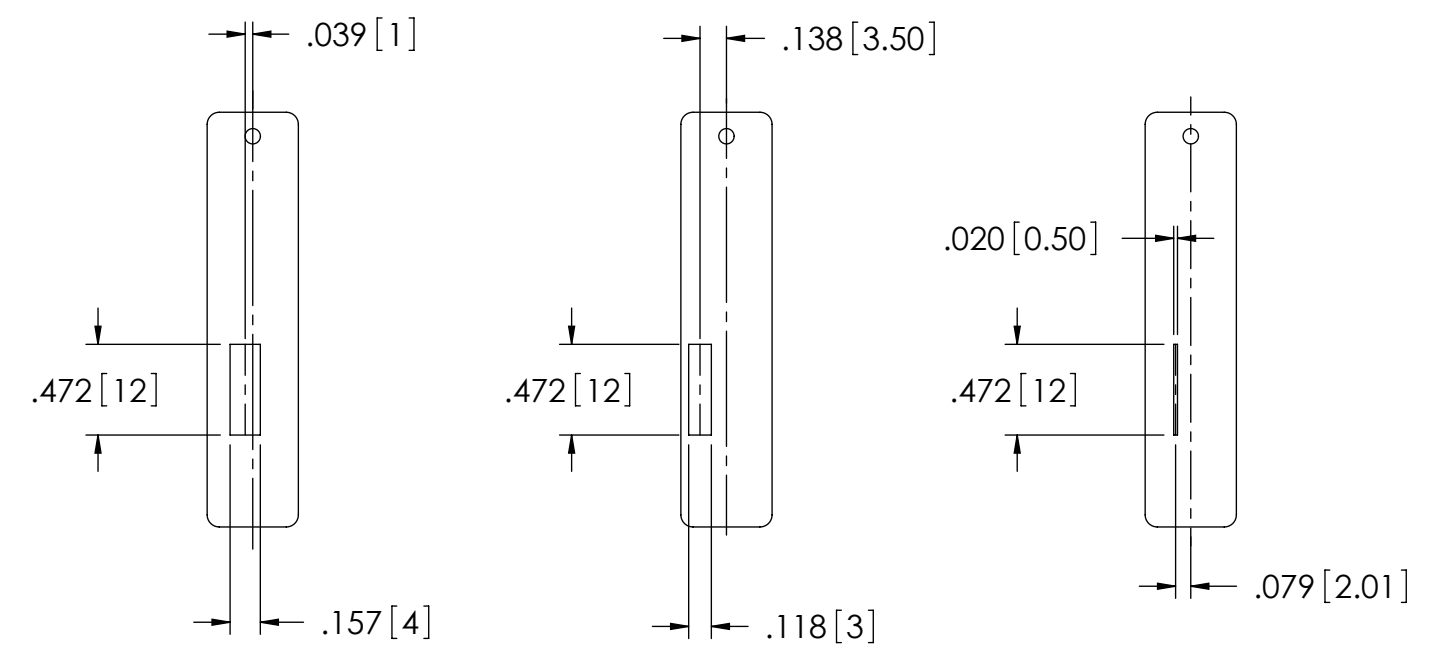
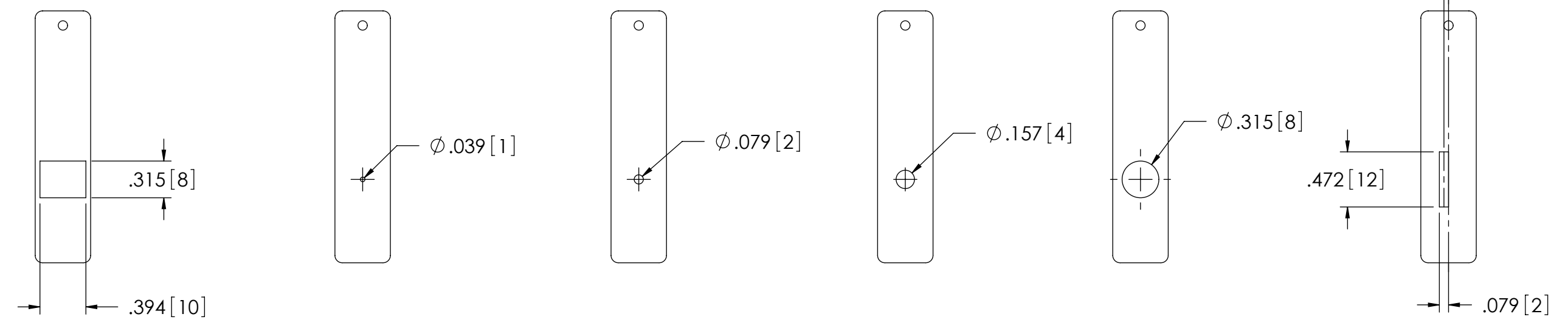

- NOTES:
- MATERIAL: .012 THK PHOSPHOR BRONZE
 - ALL DIMENSIONS ARE TYPICAL UNLESS OTHERWISE NOTED

THIS DOCUMENT CONTAINS PROPRIETARY INFORMATION AND MAY NOT BE REPRODUCED OR DISCLOSED IN WHOLE OR IN PART WITHOUT WRITTEN AUTHORIZATION FROM QUANTUM NORTHWEST		QUANTUM NORTHWEST SPOKANE WASHINGTON	
DIMENSIONS ARE IN INCHES UNLESS OTHERWISE NOTED TOLERANCES ARE: DECIMALS ANGLES .XX = ± .02 X° = ± 1° .XXX = ± .003	APPROVALS	DATE	SLITS, FLASH 300
	DRAWN SCH	061099	
	ENG		
MFG			
THIRD ANGLE	SCALE: 1:1	SIZE C	DWG NO. 24257
DO NOT SCALE OFF DRAWING	SH C:\CAD FILES*-24257		REV. 3 SHEET 1 OF 1