

REVISIONS			
REV.	DESCRIPTION	DATE	APPROVED
4	ADD 1 & 2mm HORIZ. SLITS, 10 WAS 12	4/15/2004	SH
5	UPDATE CHEMART SHEET	1/16/2015	SH

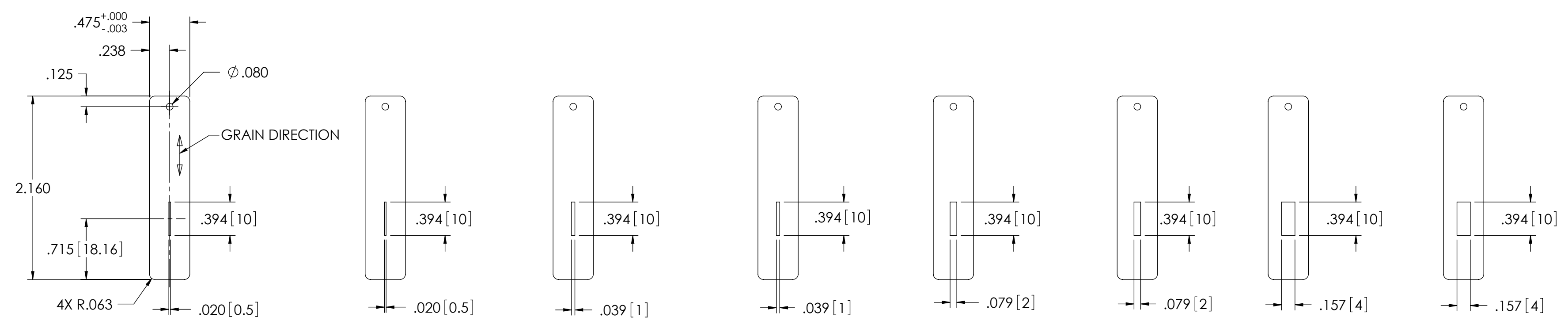

NOTE 2

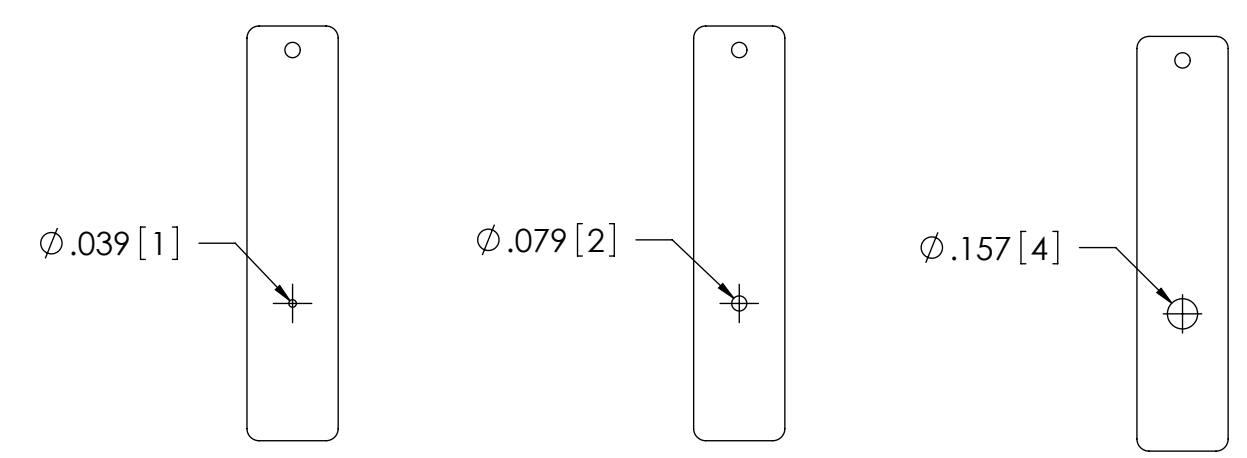
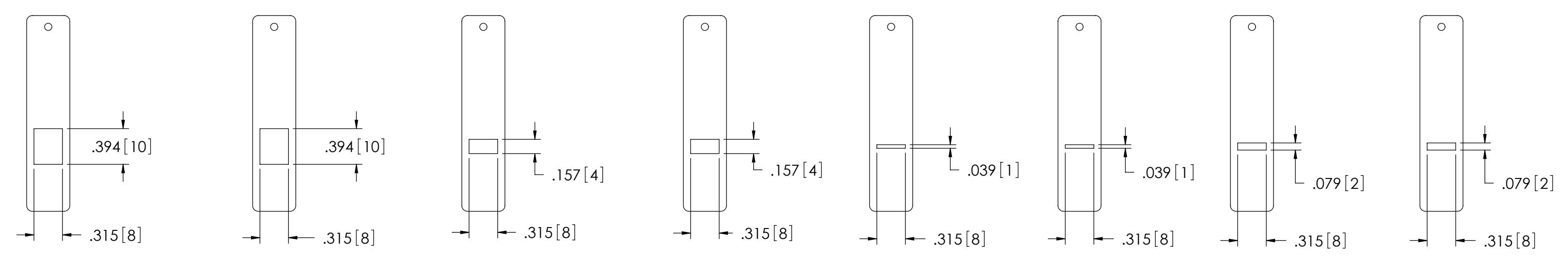

- NOTES:
1. MATERIAL: .012 THK PHOSPHOR BRONZE
 2. ALL DIMENSIONS ARE TYPICAL UNLESS OTHERWISE NOTED

THIS DOCUMENT CONTAINS PROPRIETARY INFORMATION AND MAY NOT BE REPRODUCED OR DISCLOSED IN WHOLE OR IN PART WITHOUT WRITTEN AUTHORIZATION FROM QUANTUM NORTHWEST		QUANTUM NORTHWEST SPOKANE WASHINGTON	
DIMENSIONS ARE IN INCHES UNLESS OTHERWISE NOTED TOLERANCES ARE: DECIMALS ANGLES .XX = ± .02 X° = ± 1° .XXX = ± .003	APPROVALS	DATE	SLITS, LUMA 40
	DRAWN SCH	111300	
	ENG		
MFG			SIZE C DWG NO. 24495 REV. 5
THIRD ANGLE	SCALE: 1:1	DO NOT SCALE OFF DRAWING SH C:\CAD FILES*-24495 SHEET 1 OF 1	