

Instruction Manual

FLASH 300™ Cuvette Holder for Laser Spectroscopy



Table of Contents

FLASH 300 Temperature-Controlled Cuvette Holder	2
System Setup	2
System Operation	3
Photoacoustics Option	5
Error Conditions	6
Temperature Specifications	6
Other Specifications	7
Appendix: Serial Communications for Quantum Northwest Temperature Controllers	9
Temperature Performance Certificate	14

FLASH 300 Fluorescence Cuvette Holder

Manual Version 07-13-11

The FLASH 300 is a stand-alone cuvette holder is designed for laser experiments such as pump-probe studies, flash photolysis, fluorescence, and pulsed-laser photoacoustics. The FLASH 300 cuvette holder consists of an insulated, temperature-controlled housing which holds a standard 1-cm square cuvette. It has four optical ports, 10 mm wide by 12 mm high, that may be fitted with slits to limit stray light and to further enclose the sample for temperature control. A vertical translation assists in matching sample height with the laser beam. A micrometer-driven horizontal adjustment permits fine adjustments of the position of the cuvette relative to optical sources or detectors. Variable speed magnetic stirring is provided. A removable access plug provides direct access to the surface of the cuvette for mounting transducers or specialized optics. A dry gas purging system keeps cuvette surfaces free of condensation and further purges under the opaque lid, isolating the top of the cuvette from the ambient environment. Each FLASH 300 is provided with the TC 125 Temperature Controller, a microprocessor-based controller using a modified PID algorithm.

SYSTEM SETUP

1. Fasten the FLASH 300 to your work table. The slots in the base are designed to accommodate ¼-20 screws for mounting on a standard breadboard or optical table with tapped holes on 1-inch centers or on a metric surface using M6 screws on 25 mm centers.
2. Using the 15-pin, VGA-type cables provided, connect the cuvette holder to the back of the temperature controller.
3. Connect a water source to the water connections on the cuvette holder. Flow direction is not

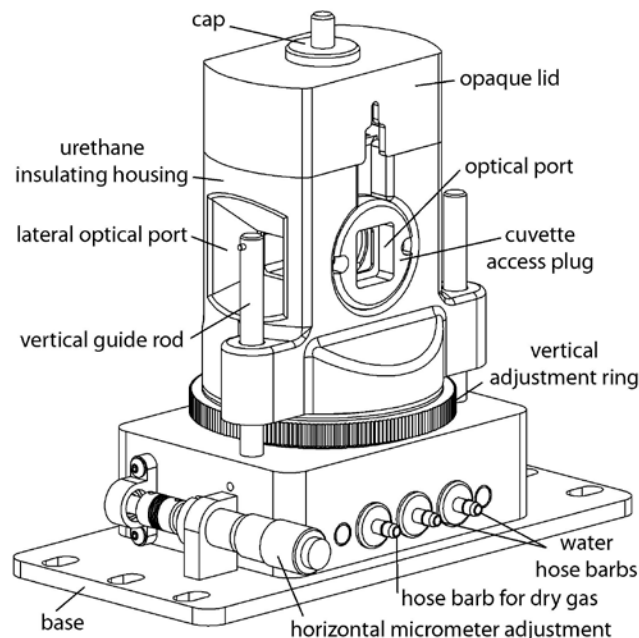

Figure 1. FLASH 300 cuvette holder

important. Typically this flow is provided from a submersible pump in a small reservoir, a temperature-controlled water bath or from a tap to a drain. Use a length of tubing with 1/8" (3mm) inside diameter such as the vinyl tubing provided.

If you purchased the optional BATH 100, simply attach one tube to the brass fitting on the top of the submersible pump let the other tube hang back in the bucket. Put water in the bucket to cover the pump and add ice if low temperatures are to be achieved.

Do not exceed an input water pressure of 25 psi (1.7 bar), as damage may occur inside the FLASH 300.

4. Set and maintain a cooling water flow rate of about 200 - 300 ml per minute. This flow should

require a pressure of approximately 3 - 5 psi (0.2 - 0.3 bar). If a circulating bath is used as the water source, it may not be possible to maintain this flow rate. However, a slower rate will likely be adequate for low temperature work, if pre-cooled circulating water is used.

Cooling water flows through a heat exchanger and removes heat from the thermoelectric device when the temperature of the holder is being lowered. Insufficient flow will allow the heat exchanger temperature to rise. If the temperature of the heat exchanger exceeds a certain cutoff value, temperature control will be automatically shut down to protect the holder.

Cooler circulating water can result in improved performance of the cuvette holder at low temperatures, whereas warmer water can improve performance at very high temperatures. For temperatures below about -25 °C, we recommend 50% methanol-water at a temperature within about 25 to 30 °C of the lowest temperature to be used. We do not recommend ethylene glycol mixtures for low temperature work, because its high viscosity reduces flow rates. **Do not use warm or room temperature water when setting temperatures near room temperature, as temperature instabilities are likely to arise.**

5. If needed, connect a source of dry gas (typically dry nitrogen or air that has passed through a desiccant) using a length of tubing with 1/8" (3mm) inside diameter, to the hose barb labeled "gas" on the side of the FLASH 300. A flow of gas must be used to prevent condensation on the faces of the cuvette when working below the dew point temperature. Set the dry gas flow rate to 50 - 200 cc/min.

6. Connect the Temperature Controller to a power source and to the FLASH 300 using the electrical cords provided.

SYSTEM OPERATION

1. Turn on the power to the FLASH 300 system using the switch located on the left side of the rear panel of the temperature control unit. When the TC 125 is turned on, the display briefly indicates the software version number running in the microcontroller and an ID number that identifies the kind of sample holder that is being controlled (see further information Appendix 1).

Note: The FLASH 300 is intended to hold a cuvette with a standard wall thickness of 1.25 mm and total width of 12.5 mm. Cuvettes with unusually thick walls will not properly fit and may damage the holder. Also, unusually short cuvettes will be difficult to remove after being pushed all of the way to the bottom of the holder.

2. Place the cuvette and sample in the sample holder.

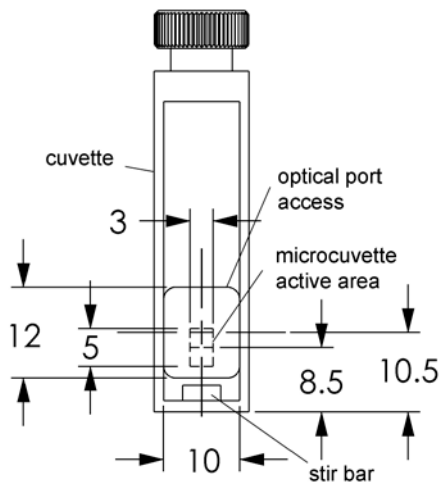

Figure 2. Cuvette geometry

Figure 2 shows the cuvette geometry. The optical ports of the FLASH 300 provide rectangular access to the cuvette, 12 mm high by 10 mm wide (with rounded corners). The center of a port is 10.5 mm above the bottom surface of the cuvette. As the FLASH 300 is adjusted vertically, this center of the port may range from 85 to 113 mm above the surface of the table on which the FLASH 300 is

mounted. For a 10 x 10 mm square cuvette, use a liquid volume of at least 1.75 mm to fill the optical window. The FLASH 300 may be also used with standard microcuvettes with a z-height of 8.5 mm. The small rectangle in the center of Figure 2 shows where the 3 mm by 5 mm active area of a 30 μ l microcuvette would be located relative to the optical port.

Note in Figure 3 that the possible angular access to the cuvette depends on the optical port being used.

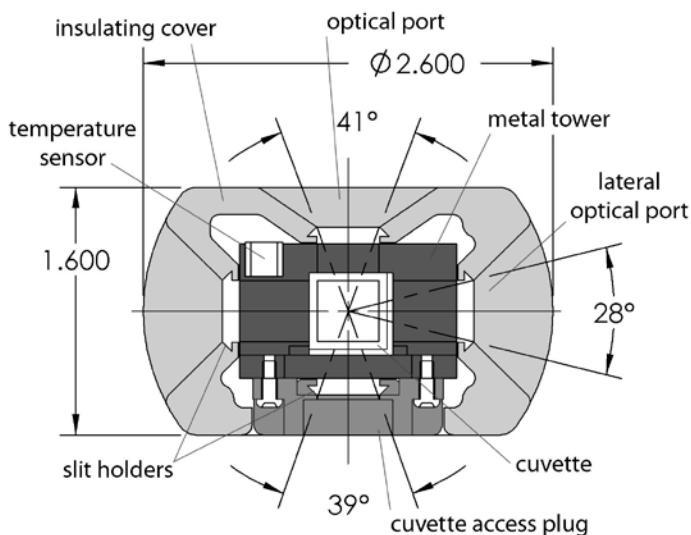

Figure 3. Horizontal cross section

The lateral ports are typically used for collimated light sources, whereas the optical ports on the other sides have greater access for arc sources or light collection with lenses.

3. Adjust the position of the cuvette using the vertical adjustment ring and the horizontal micrometer until the excitation beam illuminates the cuvette in the desired manner. For precise alignment it may be useful to use a small alignment laser and the 1 mm round aperture provided with the optical slits. The 1 mm aperture is centered on the window.

4. Use the provided optical slits or blanks around the cuvette in a manner that correctly limits the

excitation and emission light. This will not only limit stray light, but will improve the ability to control temperature by trapping air against the cuvette surfaces. However, frost is likely to form on slits at very low temperatures and may interfere with optical measurements, if proper caution is not exercised.

5. If needed, place the magnetic stir bar in the cuvette and turn the magnetic stirrer knob located on the front of the temperature control until the desired speed is reached.

6. Place the plastic cover over the cuvette holder.

7. To monitor the temperature inside the cuvette, simply plug a standard Series 400 or Series 500 thermistor probe into the 1/4 - inch phone plug jack located in the back of the temperature controller. Thread the probe through the hole in the plastic cover, into the cuvette, and down into a position in the solution out of the way of the beam and the magnetic stir bar. The controller will sense the presence of the probe and display the measured temperature. This thermometer function is calibrated against a Series 400 probe and will have the result will have the same specifications typical of these standard probes. If the accurate temperature is needed, then the probe should be calibrated for use in your experiment. These standard probes are manufactured by Yellow Springs Instrument Company (YSI), Digi-Sense and Omega. (We prefer the YSI model 423.) They are readily available through common laboratory suppliers.

8. If the hole in the plastic cover is unencumbered by a thermistor probe or other hardware, insert the access hole cap.

9. Set the target temperature using the up/down buttons located to the right of the display window. The normal temperature range is about -10 °C to +105 °C. Lower temperatures generally require additional insulation and windows to prevent condensation on the cuvette. We can provide a

Windowed Jacket for this purpose (see Figure 3). Lower temperatures also require pre-cooled circulating fluid with a temperature within 25 °C or so of the target temperature to draw heat from the Peltier device. The temperature controller can control temperatures down to -55 °C. Contact us if you would like suggestions on how to control very low temperatures.

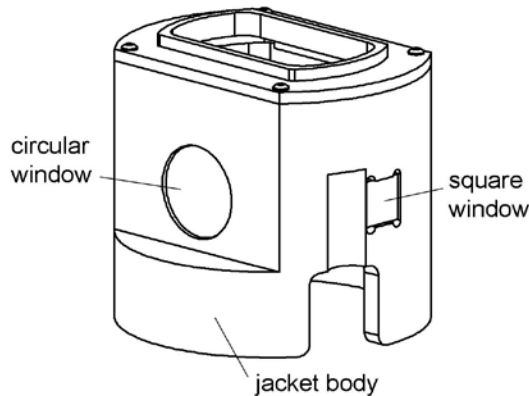

Figure 3. Windowed Jacket for the FLASH 300

If there is no external probe plugged into the rear of the unit, the TC 125 displays the *holder* temperature, the precise temperature measured in the metal body of the cuvette holder, and the *target* temperature, the temperature that the controller is attempting to achieve. The *holder* temperature sensor is located at cuvette window height on one of the corners of the cuvette tower. If a probe is being used, then the controller displays instead the *holder* temperature and the *probe* temperature. To see the *target* temperature, briefly touch either the up or down arrow button.

10. To begin controlling the temperature, depress the run/stop button located to the left of the display. Depressing the run/stop button a second time will turn temperature control off.

11. When the sample holder approaches the target temperature, the red light located on the upper left corner of the front panel of the temperature controller, will flash slowly.

12. When the sample holder reaches and remains within ± 0.02 °C of the target temperature, the red light will remain constant.

13. After measurements are completed, depress the run/stop button to stop temperature control, and turn off power and water sources.

PHOTOACOUSTICS OPTION

Optional hardware is available for use of the FLASH 300 for pulsed-laser photoacoustics

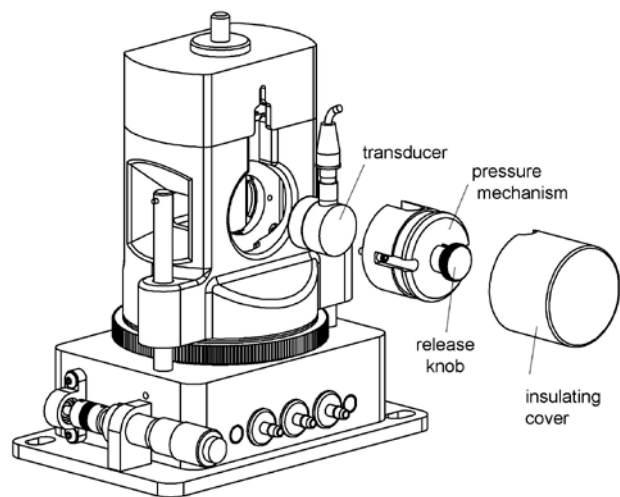

Figure 4. The photoacoustics option

Attaching the Photoacoustics Option

1. Place the cuvette and sample in the FLASH 300™.

2. Pull back the release knob on the pressure mechanism and cock it into position by rotating the knob a quarter of a turn to rest the pin on the outside of the housing. See Figure 4.

3. Place the transducer, with cable attached, in the pressure mechanism.

4. Hold the pressure mechanism so that the surface of the transducer is horizontal, and apply a small amount of acoustic couplant evenly to the surface of the transducer.

5. Screw the pressure mechanism onto the side of the FLASH 300™ using the Allen-head screwdriver provided for this purpose.

6. Gently apply pressure to the transducer-cuvette interface by rotating the release knob and slowly allowing the pin to fall into the grooves in the housing. Make sure the rubber boot on the cable seats properly into the groove on the main cover.

7. Place the insulating cover over the pressure mechanism.

Using the Photoacoustics Option

1. Attach the Photoacoustics Option and establish the transducer-cuvette interface as described above.

2. Use a preamplifier and digitizing oscilloscope to capture and digitize photoacoustic wave forms. Any waveforms from samples that must be directly compared (such as reference and sample waveforms) should be completed before altering the transducer-cuvette interface. Therefore the cuvette should be washed *in situ* between different samples.

3. After completing an experiment, the cuvette may be removed by cocking the release knob. However, if a new transducer-cuvette interface is needed, it is best to remove the entire pressure mechanism and reestablishing the interface before beginning the next experiment.

Acoustic Couplants

In our laboratory, we routinely use about 5 μ l mineral oil as an acoustic couplant. The relatively low viscosity of mineral oil results in a rapid establishment of a stable couplant interface. Mineral oil, however, has a tendency to run down the face of the transducer, while the user is attempting to make the contact. Other acceptable couplants include gels sold specifically for this purpose (for example, contact Panametrics, Inc., Waltham, MA) or honey. We do not recommend

the use of silicon grease, because its very high viscosity prevents the formation of a stable interface.

ERROR CONDITIONS

Rapid flashing of the red light indicates an error condition. The common errors that will display are:

Error conditions E5, E6 and E7 – Check Cables.

One or more of these error conditions is likely to arise if the electrical connection between the Temperature Controller and the FLASH 300 is not secure. In this case, turn off the power to the unit, check the cable, turn on the power, and resume work.

Error condition E8 – Low water flow. This error condition indicates that the heat exchanger on the thermoelectric cooler is getting too warm. This heating will occur if insufficient cooling water is flowing into the device. Error condition E8 will automatically shut down temperature control to prevent damage to the unit. If this occurs, improve cooling water flow and re-start temperature control.

If correcting these problems does not solve the error messaging, or if other errors are displayed, contact Quantum Northwest by calling (509) 624-9290 or by e-mailing us at quantum@qnw.com.

TEMPERATURE SPECIFICATIONS

Maximum Temperature. The FLASH 300 system is limited to temperatures below 105 °C. A higher target temperature cannot be set since such temperatures may damage internal components. This maximum can be attained with coolant at 15 °C or above.

An extended version (FLASH 300/E), capable of temperatures up to 150 °C and down to -55 °C, is also available.

Minimum Temperature. While the FLASH 300 system is capable of operation as low as -40 °C, the minimum useful temperature depends on the conditions under which it is used.

1. Without special conditions, using room temperature coolant, the minimum is the dew point temperature of the air at the location of use (roughly 5 °C). Below the dew point temperature, condensation on the cuvette windows will interfere with measurements.
2. With a dry gas flow rate of at about 200 cc/min into the gas inlet of the sample holder, the minimum temperature is about -10 °C. Below -10 °C there is a risk of frosting of the cuvette surfaces.
3. When mounted in an enclosure purged with dry gas and using ice water as coolant, the minimum temperature is about -25 °C. An example of such an enclosure is the sample chamber of some spectrophotometers. Lacking a purged enclosure, dry gas flow into the sample holder in combination with a windowed jacket (QNW product WJ-300), to further isolate the cuvette from outside air, will allow temperatures as low as -25 °C.
4. The minimum temperature of -40 °C can only be attained using dry gas flow, a windowed jacket, and coolant temperatures no more than 25 °C above the target temperature (typically using a refrigerated bath and methanol-water mixtures).

Probe Temperature Range. The TC 125, TC 225 and TC 425 temperature controllers accept standard 400 and 500 Series thermistor probes. These probes may be obtained from supply companies such as Cole Parmer (coleparmer.com). Standard 400 Series temperature probes will measure the temperature within ± 0.2 °C over the range of 0.0 to 70.0 °C. The probe will operate over the full range of -40 °C to +105 °C, but an individual probe will need to be calibrated by the user outside of the 0.0 to 70.0 °C range. The 500 Series probes are less standardized and may require calibration by the user. 500 Series probes may be convenient, because they are available in very small diameters.

OTHER SPECIFICATIONS

Optical access. The FLASH 300 holds a standard 1 cm square cuvette and precisely maintains its temperature. Access is provided on 4 sides through optical ports 10 mm wide by 12 mm high. Optical slits for the FLASH 300 are provided with a variety of rectangular openings (see Figure 5). For experiments requiring optical access to only two of the windows, insulating blanks, which are provided, may be used to cover the remaining two windows.

Vertical adjustment. The height of the optical centerline can be varied from 85 to 113 mm above the table.

Coarse horizontal adjustments. Horizontal position adjustments are possible using slots provided for mounting screws in the base plate. The base plate is designed to fit either metric tables with 25 or 50 mm M6 hole spacing or tables with English dimensions with 1 or 2 inch 1/4-20 hole spacing.

Fine horizontal adjustment. A micrometer adjustment moves the cuvette in one dimension front to back approximately ± 5 mm for precise beam positioning in the sample.

Variable speed magnetic stirring is provided for experiments in which it is important to rapidly remove photoproducts from the illuminated volume. A stir bar is included.

A dry gas purge is provided. The gas travels through the base of the cuvette holder for temperature equilibration and then blows onto each of the four faces of the cuvette. The gas purge minimizes condensation on the cuvette surfaces. A clear cap with access hole covers the top of the cuvette to provide isolation from the ambient environment

An optional serial interface is available for remote computer control (see Appendices).

Figure 5. Optical slits provided with the FLASH 300

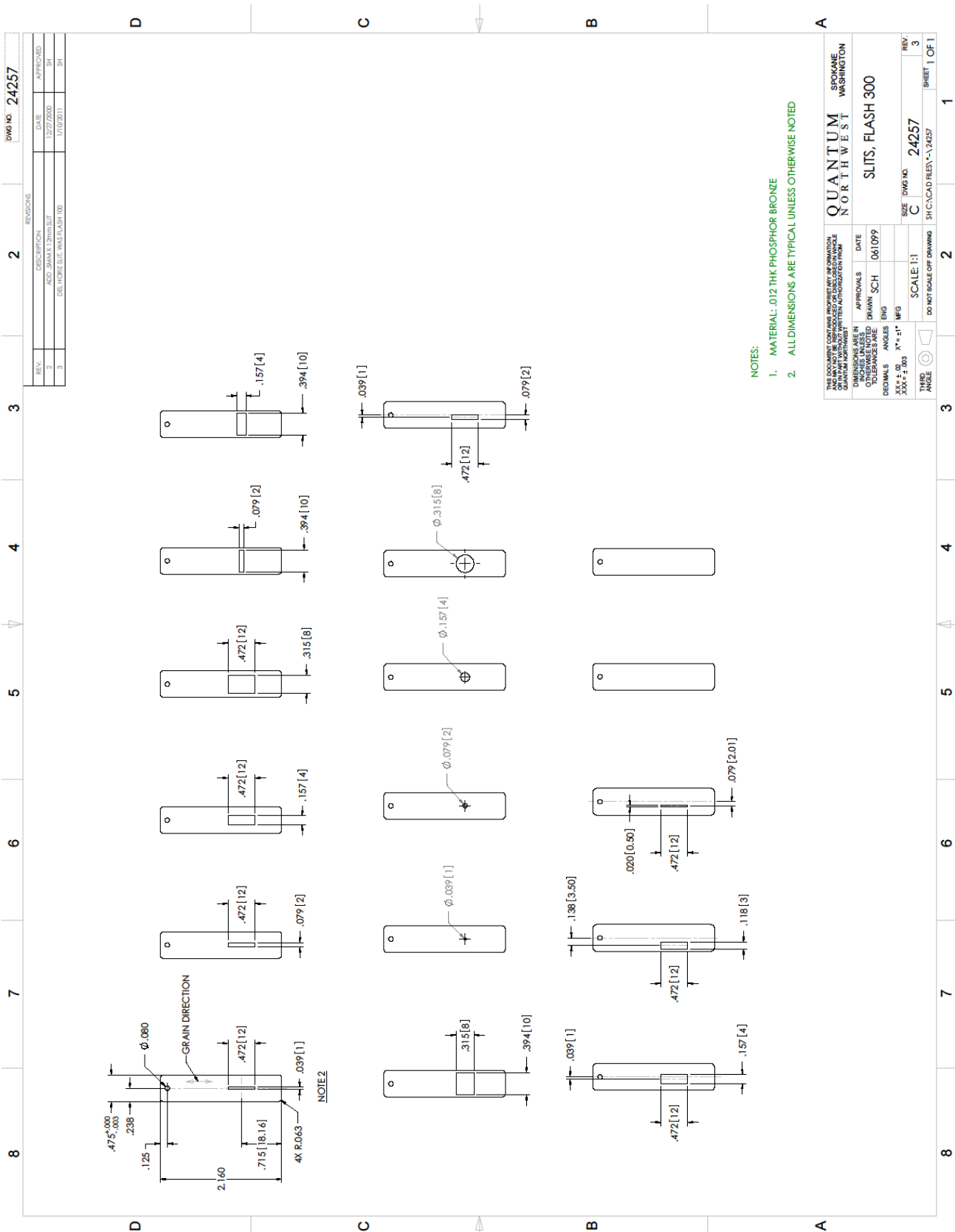

Appendix- Serial Communications for Quantum Northwest Temperature Controllers

This document provides the serial communications protocols for version 9.1 of the firmware on temperature controllers TC 125, TC 225 and TC 425.

The version number and the ID (see below) are shown briefly on the display when the temperature controller is turned on.

With the exception of setting the rate of stirring, all functions of the temperature controller can be managed from a computer, using the command set described below. If you purchased your unit as a component of a spectrometer from certain manufacturers, this feature may be implemented through traditional RS232 serial connectors on the computer and the controller. In this case they will be connected by a standard 15-pin serial extension cable (male connector on one end and female on the other). No driver installation should be needed.

Otherwise the serial linkage will be established through a USB connection between the computer and the controller. In this case the controller includes electronics which convert the USB connection to a serial communications port. However, for the port to be available to programs on the computer it will be necessary to load driver software. It is important that the driver software be loaded before connecting a USB cable between the controller and the computer. Contact Quantum Northwest for further information.

Quantum Northwest can provide a control program written specifically for control of all functions of the temperature controllers. Ask for program T-App.

To communicate with the controller, one must adhere to the conventional notation: 8/N/1.

Baud: 19200
Data Bits: 8
Parity: None
Stop Bit: 1
Flow Control: None

For many of the commands listed below the controller returns information in response to the command. All commands and responses are delineated by left and right square brackets ([]). In this document an ellipsis (.....) is used to distinguish responses from commands. Any text sent to the controller not enclosed within brackets will be ignored.

[command]	purpose of the command (sent to the controller)
..... [reply]	meaning of the reply (received from the controller)

1. Identify

[F1 ID ?] What is the ID number of the sample holder being controlled?
..... [F1 ID 31] Sample holder is a four-position turret with probe capability.

Assigned Identities:

ID = 10 - single cuvette holder
11 - single cuvette holder with probe capability
12 - high temperature single cuvette holder
20 - dual cuvette holder
21 - dual cuvette holder with probe capability
22 - dual-controlled titrator
30 - 4-position turret
31 - 4-position turret with probe capability
32 - 6-position turret (or linear cell) changer

Identity Classes:

(10 – 13) - single sample holder using a TC 125 controller
(20 – 22) - two sample holders using a TC 225 controller
(30 – 31) - multiple cuvette holder using a TC 425 controller
(32) - multiple cuvette holder using a TC 125 controller,

2. Controller Firmware Version

[F1 VN ?] What is the version number of the controller firmware?
 [F1 VN 9.1] The controller is operating firmware version number 9.1.

3. Stirrer

[F1 SS +] Turn stirrer on. (Stir rate must be set manually.)
 [F1 SS -] Turn stirrer off.

4. Temperature Control

[F1 TC +] Turn temperature control on.
 [F1 TC -] Turn temperature control off.

5. Target Temperature

[F1 TT S 23.10] Set target temperature to 23.10 °C.
 [F1 TT ?] What is the current target temperature?
 [F1 TT 71.32] Target temperature is 71.32 °C.
 [F1 TT +] Turn on automatic reporting of manual changes to the target temperature
 [F1 TT -] Turn off automatic reporting of manual changes to the target temperature
 [F1 MT ?] What is the maximum target temperature allowed
 [F1 MT 110] The maximum target temperature allowed is 110 °C
 [F1 LT ?] What is the lowest target temperature allowed
 [F1 LT -30] The lowest target temperature allowed is -30 °C

6. Instrument Status

[F1 IS ?] What is the current instrument status?
 [F1 IS 0-+S] Response is four parameters:
 number of unreported errors is 0 (0 to 9)
 stirrer is off (+ is on, - is off)
 temperature control is on (+ is on, - is off)
 temperature is stable (S is stable, C is changing)
 [F1 IS +] Automatically report instrument status whenever it changes
 (e.g., due to manual changes at controller)
 [F1 IS -] Stop periodic or automatic reports of instrument status.
 [F1 IS R] The controller has been powered off and back on again.

7. Heat Exchanger Temperature

[F1 HL ?] What is the high temperature limit for the heat exchanger
 [F1 CT 60] The heat exchanger high temperature limit is 60 °C

[F1 HT ?] What is the current temperature of the heat exchanger?
..... [F1 CT 39] The current heat exchanger temperature is 39 °C.
[F1 HT +3] Automatically report heat exchanger temperature every 3 seconds
[H1 CT -] Stop periodic heat exchanger temperature reports.

8. Current Temperature

[F1 CT ?] What is the current temperature of the holder?
..... [F1 CT 22.84] The current temperature is 22.84 °C.
[F1 CT +3] Automatically report current temperature every 3 seconds.
[F1 CT -] Stop periodic current temperature reports.

9. Probe Status

[F1 PS ?] Is there an external temperature probe connected?
..... [F1 PR +] A probe is connected.
..... [F1 PR -] No probe is connected.
[F1 PS +] Enable probe status to be sent automatically when a probe is installed or removed. This is the default.
[F1 PS -] Disable automatic sending of probe status.
[F1 PT ?] What is the current probe temperature?
[F1 PT +3] Automatically report the probe temperature every 3 seconds.
..... [F1 PT 22.3] The current probe temperature is 22.3 degrees.
..... [F1 PT NA] Probe temperature is not available.
[F1 PT -] Stop automatic probe temperature report.
[F1 PA S 0.5] Set the increment for automatic reporting of the probe temperature to 0.5 degrees during a ramp. (Increment must be positive) without sign in tenths between 0.1 and 9.9 degrees and will work for ramps going up or down.)
[F1 PA +] Start automatic reporting of probe temperature every temperature increment.
..... [F1 PT 30.5] The current probe temperature is 30.5 degrees.
[F1 PA -] Stop automatic reporting of probe temperature every temperature increment.
[F1 PX +] Change probe temperature returned to a precision of 0.01 degree.

10. Error Reporting

[F1 ER ?] Report the current error. For a more complete description, see "Error Codes" in the help system of the Serial Control Program.
..... [F1 ER -1] No current error
..... [F1 ER 05] Cell T out of range (Loose cable? Sensor failure?)
..... [F1 ER 06] Cell & heat exchanger T out of range (Loose cable?)
..... [F1 ER 07] Heat exchanger T out of range (Loose cable? Sensor failure?)
..... [F1 ER 08] Inadequate coolant (check flow). Temperature control has shut down.
..... [F1 ER 09] Syntax error on a preceding command.
[F1 ER +] Automatically report errors when they occur
[F1 ER -] Stop automatic error reports

11. Temperature Ramping

- [F1 RS S 3] Set the time increment to 3 seconds (must be a positive integer).
[F1 RT S 10] Set the temperature increment to 0.1 °C (a positive integer, units are hundredths of a degree).
[F1 TL +] Ramp the sample and reference identically.
[F1 TL -] Ramp the sample while the reference remains stable.

The default is to ramp the sample while the reference remains stable. There is no query for this setting. Ramping both the sample and reference at different rates or to different target temperatures (see below) is not possible.

The ramp rate (°C/min) is calculated as $(RT / 100) / (RS / 60)$. Ramp rates corresponding to selected RS and RT pairs are given in the table below.

°C/min	0.05	0.1	0.2	0.5	1	2	5	10
RS	12	12	6	6	3	3	3	3
RT	1	2	2	5	5	10	25	50

Note: For the higher ramp settings, the observed rate may be lower than that calculated from RT and RS or it may be nonlinear over part of the temperature range because the maximum possible rate of heating or cooling is limited (and dependent on the temperature).

To Ramp the temperature:

1. equilibrate at the starting temperature,
2. set the time (RS) and temperature (RT) increments,
3. set a new target temperature.

The new target may be above or below the current temperature and, as soon as it is set, the ramp will begin, up or down, to that new target.

After reaching the target the controller will hold at that temperature. At any time RS and RT may be reset and a new ramp initiated by setting another target temperature.

Once you are done, terminate ramping by resetting both RS and RT to 0. Otherwise, setting a new target temperature later will initiate a ramp to that target temperature.

12. Cell Changing

The commands in this class will have no effect unless the sample holder has multiple positions. This includes all TC 425 controllers (4 positions with buttons on the controller that can be used to change the position manually) and some TC 125 controllers (more than 4 positions and no buttons, so software must be used to control the position setting).

- [F2 DI] Device initialize: move to home position.
[F2 PI] Device initialize: move to home position and reply when done.
..... [F2 OK] Device is finished moving.
[F2 DL 3] Device locate: move to position 3. (Device must be initialized prior to using this command.)
[F2 PL 6] Device locate: move to position 6 and reply when done.
..... [F2 DL 6] Device is now in position 6.
[F2 ?] Report status of device.
..... [F2 OK] Device is ready to accept commands.
..... [F2 BUSY] Device is busy running commands.

[F2 PL ?] What is the device location (position)?
..... [F2 DL 2] Device is in position 2. (If reply is 0, device is not initialized.)
[F2 DD 2] Set speed to 2 (acceptable range 2-250 with 2 being fast, 250
 being slow).
[F2 DD ?] What is the current device speed?
..... [F2 DD 2] Device is set to speed setting 2. If reply is 0, then the firmware
 default value (which depends on the sample holder) is being used.

13. Reference Cuvette (TC 225 only)

[R1 ...]

To control the temperature of the reference cuvette of a Dual Temperature Controller, use any commands in classes 3-8, substituting R1 for F1. There are no corresponding [R1 ...] commands for classes 9 – 11.

If you wish to ramp the temperature of the reference and sample cuvettes together, please note the linking command [F1 TL +] in command class 11.