

# Instruction Manual

---

**qpod<sup>®</sup>**

## **Temperature-Controlled Sample Compartment for Fiber Optic Spectroscopy**

---



# Table of Contents

<b>qpod Temperature-Controlled Sample Compartment for Fiber Optic Spectroscopy</b>	<b>2</b>
Overview	2
Items Included with Your Purchase	2
System Setup	3
Optics	3
System Operation	5
Error Conditions	6
Serial Control for the <b>qpod</b>	6
Temperature Specifications	6
Other Specifications	7
Optical slits provided with the <b>qpod</b>	8
<b>Appendix: Serial Communications for Quantum Northwest Temperature Controllers</b>	<b>9</b>
<b>Temperature Performance Certificate</b>	<b>14</b>

# qpod Temperature-Controlled Sample Compartment for Fiber Optic Spectroscopy

Manual Version 07-13-11

## OVERVIEW

The **qpod** is a complete sample compartment for fiber optic spectroscopy, including a Peltier-controlled cuvette holder with magnetic stirring, and fused silica lens systems with SMA fiber optic connectors.

You have purchased one of three **qpod** packages. The **CUV-qpod-ABSKIT** provides collimating optics to pass light straight through for absorbance, transmittance or turbidity measurements. The **CUV-qpod-FLKIT** provides imaging lens systems for excitation and detection of fluorescence emission at right angles. The **CUV-qpod-MPKIT** is a multipurpose kit with a combination of optics that may be used for either absorbance or fluorescence measurements.

The **qpod** is constructed of a single molded housing. A Peltier-controlled cuvette holder in the center provides temperature control and variable speed magnetic stirring, and holds optical slits for limiting light access to the cuvette as needed. A dry gas purge may be used to minimize condensation when working at low temperatures. SMA fiber optic connections and high quality fused silica optics may be inserted in different combinations into optical ports in the walls surrounding the cuvette holder. Accessories such as polarizers and filter holders may be inserted in the light paths. Spherical mirrors may be used to enhance excitation or emitted light. All optics provide focusing and position adjustments for maximizing signal throughput.

## ITEMS INCLUDED WITH YOUR PURCHASE

### A. qpod and Optics Package

1. **qpod** with lid and cap

2. one of three optical kits:
  - ABSKIT** - optics for absorbance or transmission measurements:
    - a. 2 QCL-UV collimating lenses
  - FLKIT** - optics for fluorescence measurements:
    - a. 2 QIL-UV imaging lenses
    - b. 2 QMP mirror plugs
  - MPKIT** - multipurpose kit:
    - a. 2 QCL-UV collimating lenses
    - b. 2 QIL-UV imaging lenses
    - c. 2 QMP mirror plugs
3. **plastic utility box** containing:
  - a. 5/64-inch hex driver
  - b. set of optical slits
  - c. stir bar
  - d. 2 blanks for unused optical ports

### B. Temperature Controller

1. **TC 125** Temperature Controller
2. **qpod** manual
3. **electrical cable** to connect the TC125 to the **qpod**
4. **power cord** for the Temperature Controller
5. **If you ordered** the **SER 2.2** option, you will also find:
  - a. CD with the program Serial Control V2.2
  - b. USB cable to connect the Temperature Controller to your computer

### C. BATH 100

1. **submersible pump**
2. **plastic bucket**
3. **a length of tubing**

**D. Optional Items** - Any optical components such as polarizers or optical filter holders

## SYSTEM SETUP

1. If desired, fasten the **qpod** down to a table or optical breadboard. The holes in the corners of the base are located and sized such that it will attach via ¼-20 screws to a table with 1-inch centers or with M-6 screws to a table with 25 mm centers.
2. Supply circulating water to the Peltier unit. Attach tubing from the submersible pump to either one of the water hose barbs on the **qpod**. Attach another piece of tubing from the **qpod** back to the bucket. Put water in the bucket, turn on the pump by plugging it into an outlet and check to be sure that water is flowing back into the bucket. Check for leaks. Unplug the pump until you have completed the remainder of the system set up.
3. If you plan to work at low temperatures, connect a source of dry gas (typically nitrogen) using a length of tubing with 1/8" (3mm) inside diameter, to the hose barb labeled "gas" on the side of the **qpod**. A flow of gas must be used to prevent condensation on the faces of the cuvette when working below the dew point temperature. Set the dry gas flow rate to 50 - 200 cc/min.
4. Attach the electrical cable between the TC 125 and the **qpod**.
5. Attach the power cord to the back of the temperature controller and plug it in.
6. Insert optics as described in the next section.

## OPTICS

There are two basic optical configurations for the **qpod**: one to measure **absorbance** and the other to measure **fluorescence**.

### Optics to measure absorbance

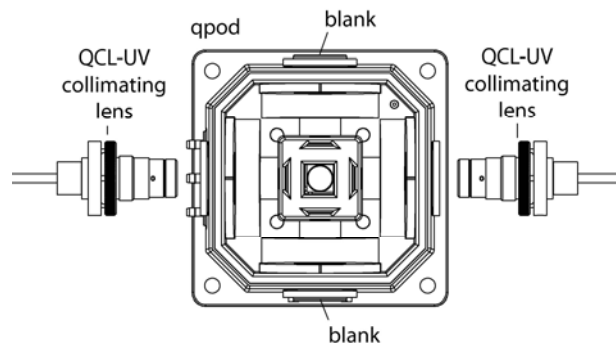

Figure 1 - Absorbance configuration

As shown in **Figure 1**, to set the **qpod** up for absorbance measurements insert collimating lens on any two opposite sides of the **qpod**. Put black plastic blanks from the **qpod** accessory kit in the other two optical ports. One lens collimates the output from the source fiber into a beam about 5 mm in diameter. The beam passes through the sample and is then focused on the collection fiber. A collimating lens assembly contains a single 6 mm diameter, 12 mm focal length, broadband AR-coated, fused silica lens whose principal point is located 12 mm from the end of the fiber.

### Optics to measure fluorescence

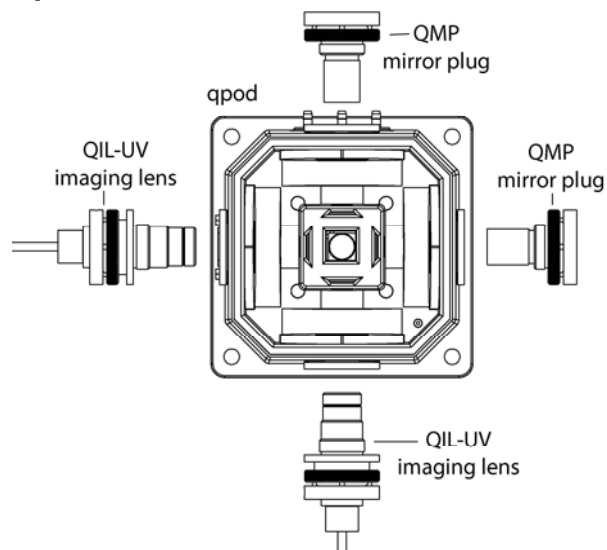
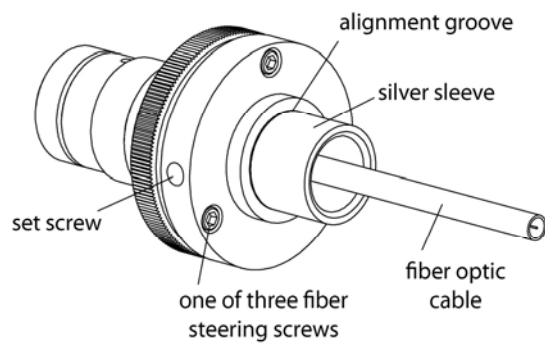

Figure 2.

As shown in **Figure 2**, to set the **qpod** up for fluorescence measurements insert an imaging lens to focus light from a source fiber into the center of the sample cuvette. Place another imaging lens at 90° to the source lens images the illuminated volume onto a collection fiber. To enhance collection efficiency, spherical mirrors may be placed on the remaining positions of the **qpod**. One opposite the excitation fiber focuses the excitation source back through the sample and another opposite the collection lens focuses extra emitted light back through the sample to roughly double the amount of emitted light collected.

An imaging lens assembly contains two ½-inch diameter, 30 mm focal length, broadband AR-coated fused silica lenses. The principal point of one lens is located 30 mm from the fiber and the principal point of the second lens is located 30 mm from the center of the cuvette. Thus the imaging lens pair creates an image of the fiber end, without magnification, in the center of the cuvette, or images the illuminated volume on a collection fiber.

### Inserting a lens into the qpod



**Figure 3** - Components of a lens assembly

1. Use the 5/64-inch hex screwdriver from the **qpod** accessory kit to loosen the set screw (**Figure 3**).
2. Remove the silver sleeve with a black end piece from the lens assembly. Set it aside.

3. Screw the empty optical assembly all the way into the appropriate position in the **qpod**. If you are using an accessory component such as a filter holder or polarizer. First place the accessory in the **qpod**. As you screw in the empty lens assembly the accessory will fit over its end and then snap into place.
4. Look for the location of the set screw. If it is in a difficult position to reach, remove the three fiber steering screws, rotate the end of the optical assembly until the set screw is accessible, and reattach the alignment assembly so the screw is more available. The steering screws compress an o-ring, permitting fine alignment of the end of the fiber relative to the lens.

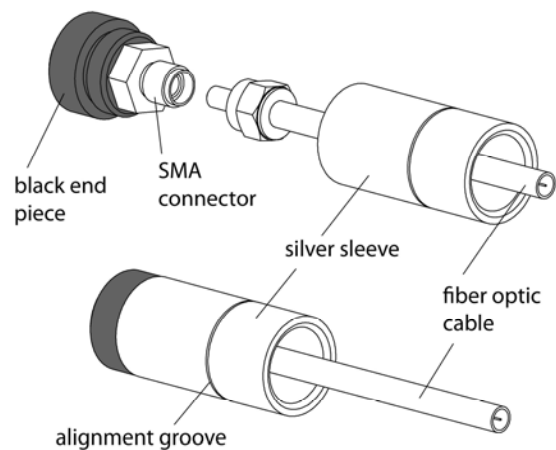

**Figure 4** - Attaching the fiber optic to the SMA connector

5. Now, unscrew the silver sleeve from the black end piece revealing the SMA connector (**Figure 4**).
6. Slide the silver sleeve over the end of the fiber optic connector and cable, leaving the threaded end toward the end of the cable.
7. Attach the fiber optic cable to the SMA connector.

8. Holding the black end piece, screw the silver sleeve back into place.
9. Insert the SMA connector and silver sleeve into the hole in the optical assembly. For a first adjustment, insert the assembly until the alignment groove is even with the face of the lens assembly. Later, you can optimize the signal intensity by sliding the SMA connector and silver sleeve in deeper.

## **SYSTEM OPERATION**

1. Use a liquid sample of at least 1.5 ml and place it in a standard 1 x 1-cm square cuvette. Place the cuvette in the cuvette holder in the center of the **qpod**. Standard microcuvettes may also be used for smaller volumes. The **qpod** is designed to hold microcuvettes in which the “z” dimension (distance between the bottom of the cuvette and the optical center line) is 8.5 mm.

**Note:** The **qpod** is intended to hold a cuvette with a standard wall thickness of 1.25 mm and total width of 12.5 mm. Cuvettes with unusually thick walls will not properly fit and may damage the holder.

2. If needed, place the magnetic stir bar in the cuvette and turn the magnetic stirrer knob located on the front of the temperature control until the desired speed is reached.
3. To monitor the temperature inside the cuvette, plug a standard Series 400 or Series 500 thermistor probe into the ¼ - inch phone plug jack located in the back of the temperature controller. Standard Series 400 and 500 thermistor probes are available from a number of suppliers. We favor the model ON-402-PP by Omega (omega.com). Thread the probe through the split rubber plug in the **qpod** cap and place it in the cuvette out of the way of the light.
4. Provide a source of light and a detector. You may maximize the signal by adjustments of the three fiber steering screws, making small

movements of the position of the fiber end relative to the lens, and by loosening the set screw to insert the silver sleeve deeper into the lens assembly. Inserting the silver sleeve further into lens assembly moves the end of the fiber closer to the lens, altering the focus of the light. This adjustment is most important at UV wavelengths.

5. Use the optical slits or blanks (provided in the **qpod** accessory kit) around the cuvette in a manner that correctly limits the excitation and emission light.
6. Put the cover and cap on the **qpod**.
7. Turn on the submersible pump by plugging it in. Cooling water flows through a heat exchanger and removes heat from the thermoelectric device when the temperature of the holder is being lowered. Insufficient flow will allow the heat exchanger temperature to rise. If the temperature of the heat exchanger exceeds a certain cutoff value, temperature control will be automatically shut down to protect the holder.

Cooler circulating water can result in improved performance of the cuvette holder at low temperatures, whereas warmer water can improve performance at very high temperatures. **Do not use warm or room temperature water when setting temperatures near room temperature, as temperature instabilities are likely to arise.** Cool the circulating water by the addition of ice to the bucket.

A circulating bath may be used to provide circulating fluid to the **qpod**. Using such a bath, temperatures well below the specified -30 °C lowest temperature may be readily achieved. Contact us for suggestions on how to achieve very low temperatures.

8. Turn on the temperature controller using the switch located on the left side of the rear panel of the temperature control unit. When the TC

125 is turned on, the display briefly indicates the software version number running in the microcontroller and an ID number that identifies the kind of sample holder that is being controlled (see further information in Appendix 1).

9. Set the target temperature using the up and down arrows. The normal temperature range is -30 °C to +105 °C. Contact us for suggestions if you would like to work at temperatures lower than -30 °C.

If there is no external probe plugged into the rear of the unit, the TC 125 displays the *holder* temperature, the precise temperature measured in the metal body of the cuvette holder, and the *target* temperature, the temperature that the controller is attempting to achieve. The *holder* temperature sensor is located at cuvette window height on one of the corners of the cuvette tower. If a probe is being used, then the controller displays instead the *holder* temperature and the *probe* temperature. To see the *target* temperature, briefly touch either the up or down arrow button.

10. To begin controlling the temperature, depress the run/stop button located to the left of the display. Depressing the run/stop button a second time will turn temperature control off. When the sample holder approaches the target temperature, the red light located on the upper left corner of the front panel of the temperature controller, will flash slowly. When the sample holder reaches and holds within  $\pm 0.02$  °C of the target temperature, the red light will remain constant.
11. If you purchased the Serial Control option, you may load the software at any time and begin using it. Instructions are found in the Help system.
12. After measurements are completed, depress the run/stop button to stop temperature control, and turn off power and water sources.

## **ERROR CONDITIONS**

Rapid flashing of the red light indicates an error condition. The common errors that will display are: **Error conditions E5, E6 and E7 – Check Cables.** One or more of these error conditions is likely to arise if the electrical connection between the Temperature Controller and the **qpod** is not secure. In this case, turn off the power to the unit, check the cable, turn on the power, and resume work.

**Error condition E8 – Low water flow.** This error condition indicates that the heat exchanger on the thermoelectric cooler is getting too warm. This heating will occur if insufficient cooling water is flowing into the device. Error condition E8 will automatically shut down temperature control to prevent damage to the unit. If this occurs, improve cooling water flow and re-start temperature control.

If correcting these problems does not solve the error messaging, or if other errors are displayed, contact Quantum Northwest by calling (509) 624-9290 or by e-mailing us at [quantum@qnw.com](mailto:quantum@qnw.com).

## **TEMPERATURE SPECIFICATIONS**

Temperature capabilities of Quantum Northwest cuvette holders depend on the product you have and the conditions under which it is operated.

**Maximum Temperature.** The **qpod** system is limited to temperatures below 105 °C. A higher target temperature cannot be set since such temperatures may damage internal components. This maximum can be attained with coolant at 15 °C or above.

**Minimum Temperature.** While the **qpod** system is capable of operation as low as -40 °C, the minimum useful temperature depends on the conditions under which it is used.

1. Without special conditions, using room temperature coolant, the minimum is the dew point temperature of the air at the location of use (roughly 5 °C). Below the dew point

temperature, condensation on the cuvette windows will interfere with measurements.

2. With a dry gas flow rate of at about 200 cc/min into the gas inlet of the sample holder, the minimum temperature is about -10 °C. Below -10 °C there is a risk of frosting of the cuvette surfaces.
3. When using ice water as coolant and dry gas flow, the minimum temperature is about -25 °C. In high humidity environments there is increased potential for frost formation even with gas flow.

**Probe Temperature Range.** The TC 125, TC 225 and TC 425 temperature controllers accept standard 400 and 500 Series thermistor probes. These probes may be obtained from supply companies such as Cole Parmer (coleparmer.com). Standard 400 Series temperature probes will measure the temperature within  $\pm 0.2$  °C over the range of 0.0 to 70.0 °C. The probe will operate over the full range of -40 °C to +105 °C, but an individual probe will need to be calibrated by the user outside of the 0.0 to 70.0 °C range. The 500 Series probes are less standardized and may require calibration

by the user. 500 Series probes may be convenient, because they are available in very small diameters.

## ***Other Specifications***

**Variable speed magnetic stirring** is provided primarily to speed up temperature equilibration. Two stir bars are included.

**A dry gas purge is provided.** The gas travels through the base of the cuvette holder for temperature equilibration and then blows onto the exposed faces of the cuvettes. The gas purge minimizes condensation on the cuvette surfaces. An opaque lid covers the tops of the cuvettes to provide isolation from the ambient environment.

**An optional serial interface** is available for remote computer control (see Appendices).

**Optical access.** The **qpod** holds a standard 1 cm square cuvette and precisely maintains its temperature. Access is provided on four sides of the cuvette through optical ports 10 mm wide by 12 mm high.



# Appendix- Serial Communications for Quantum Northwest Temperature Controllers

7/13/2011

This document provides the serial communications protocols for version 9.1 of the firmware on temperature controllers TC 125, TC 225 and TC 425.

The version number and the ID (see below) are shown briefly on the display when the temperature controller is turned on.

With the exception of setting the rate of stirring, all functions of the temperature controller can be managed from a computer, using the command set described below. If you purchased your unit as a component of a spectrometer from certain manufacturers, this feature may be implemented through traditional RS232 serial connectors on the computer and the controller. In this case they will be connected by a standard 15-pin serial extension cable (male connector on one end and female on the other). No driver installation should be needed.

Otherwise the serial linkage will be established through a USB connection between the computer and the controller. In this case the controller includes electronics which convert the USB connection to a serial communications port. However, for the port to be available to programs on the computer it will be necessary to load driver software. It is important that the driver software be loaded before connecting a USB cable between the controller and the computer. Contact Quantum Northwest for further information.

Quantum Northwest can provide a control program written specifically for control of all functions of the temperature controllers. Ask for program T-App.

To communicate with the controller, one must adhere to the conventional notation: 8/N/1.

Baud:	19200
Data Bits:	8
Parity:	None
Stop Bit:	1
Flow Control:	None

For many of the commands listed below the controller returns information in response to the command. All commands and responses are delineated by left and right square brackets ( [ ] ). In this document an ellipsis (.....) is used to distinguish responses from commands. Any text sent to the controller not enclosed within brackets will be ignored.

---

[command]	purpose of the command (sent to the controller)
.....[reply]	meaning of the reply (received from the controller)

---

## 1. Identify

[F1 ID ?]	What is the ID number of the sample holder being controlled?
.....[F1 ID 31]	Sample holder is a four-position turret with probe capability.

### Assigned Identities:

ID =	10 - single cuvette holder
	11 - single cuvette holder with probe capability
	12 - high temperature single cuvette holder
	20 - dual cuvette holder
	21 - dual cuvette holder with probe capability
	22 - dual-controlled titrator
	30 - 4-position turret
	31 - 4-position turret with probe capability
	32 - 6-position turret (or linear cell) changer

Identity Classes:

- (10 – 13) - single sample holder using a TC 125 controller
- (20 – 22) - two sample holders using a TC 225 controller
- (30 – 31) - multiple cuvette holder using a TC 425 controller
- (32) - multiple cuvette holder using a TC 125 controller,

---

**2. Controller Firmware Version**

- [F1 VN ?] What is the version number of the controller firmware?  
..... [F1 VN 9.1] The controller is operating firmware version number 9.1.

---

**3. Stirrer**

- [F1 SS +] Turn stirrer on. (Stir rate must be set manually.)  
[F1 SS -] Turn stirrer off.

---

**4. Temperature Control**

- [F1 TC +] Turn temperature control on.  
[F1 TC -] Turn temperature control off.

---

**5. Target Temperature**

- [F1 TT S 23.10] Set target temperature to 23.10 °C.  
[F1 TT ?] What is the current target temperature?  
..... [F1 TT 71.32] Target temperature is 71.32 °C.  
[F1 TT +] Turn on automatic reporting of manual changes to the target temperature  
[F1 TT -] Turn off automatic reporting of manual changes to the target temperature  
[F1 MT ?] What is the maximum target temperature allowed  
..... [F1 MT 110] The maximum target temperature allowed is 110 °C  
[F1 LT ?] What is the lowest target temperature allowed  
..... [F1 LT -30] The lowest target temperature allowed is -30 °C

---

**6. Instrument Status**

- [F1 IS ?] What is the current instrument status?  
..... [F1 IS 0-+S] Response is four parameters:  
    number of unreported errors is 0 (0 to 9)  
    stirrer is off (+ is on, - is off)  
    temperature control is on (+ is on, - is off)  
    temperature is stable (S is stable, C is changing)  
[F1 IS +] Automatically report instrument status whenever it changes  
    (e.g., due to manual changes at controller)  
[F1 IS -] Stop periodic or automatic reports of instrument status.  
..... [F1 IS R] The controller has been powered off and back on again.

---

**7. Heat Exchanger Temperature**

- [F1 HL ?] What is the high temperature limit for the heat exchanger

.....[F1 CT 60] The heat exchanger high temperature limit is 60 °C  
[F1 HT ?] What is the current temperature of the heat exchanger?  
.....[F1 CT 39] The current heat exchanger temperature is 39 °C.  
[F1 HT +3] Automatically report heat exchanger temperature every 3 seconds  
[H1 CT -] Stop periodic heat exchanger temperature reports.

---

### **8. Current Temperature**

[F1 CT ?] What is the current temperature of the holder?  
.....[F1 CT 22.84] The current temperature is 22.84 °C.  
[F1 CT +3] Automatically report current temperature every 3 seconds.  
[F1 CT -] Stop periodic current temperature reports.

---

### **9. Probe Status**

[F1 PS ?] Is there an external temperature probe connected?  
.....[F1 PR +] A probe is connected.  
.....[F1 PR -] No probe is connected.  
[F1 PS +] Enable probe status to be sent automatically when a probe is installed or removed. This is the default.  
[F1 PS -] Disable automatic sending of probe status.  
[F1 PT ?] What is the current probe temperature?  
[F1 PT +3] Automatically report the probe temperature every 3 seconds.  
.....[F1 PT 22.3] The current probe temperature is 22.3 degrees.  
.....[F1 PT NA] Probe temperature is not available.  
[F1 PT -] Stop automatic probe temperature report.  
[F1 PA S 0.5] Set the increment for automatic reporting of the probe temperature to 0.5 degrees during a ramp. (Increment must be positive) without sign in tenths between 0.1 and 9.9 degrees and will work for ramps going up or down.)  
[F1 PA +] Start automatic reporting of probe temperature every temperature increment.  
.....[F1 PT 30.5] The current probe temperature is 30.5 degrees.  
[F1 PA -] Stop automatic reporting of probe temperature every temperature increment.  
[F1 PX +] Change probe temperature returned to a precision of 0.01 degree.

---

### **10. Error Reporting**

[F1 ER ?] Report the current error. For a more complete description, see "Error Codes" in the help system of the Serial Control Program.  
.....[F1 ER -1] No current error  
.....[F1 ER 05] Cell T out of range (Loose cable? Sensor failure?)  
.....[F1 ER 06] Cell & heat exchanger T out of range (Loose cable?)  
.....[F1 ER 07] Heat exchanger T out of range (Loose cable? Sensor failure?)  
.....[F1 ER 08] Inadequate coolant (check flow). Temperature control has shut down.  
.....[F1 ER 09] Syntax error on a preceding command.  
[F1 ER +] Automatically report errors when they occur  
[F1 ER -] Stop automatic error reports

---

## 11. Temperature Ramping

**The commands in this class will have an effect only for the TC 225.**

- [F1 RS S 3]           Set the time increment to 3 seconds (must be a positive integer).  
[F1 RT S 10]          Set the temperature increment to 0.1 °C (a positive integer, units are hundredths of a degree).  
[F1 TL +]             Ramp the sample and reference identically.  
[F1 TL -]             Ramp the sample while the reference remains stable.

The default is to ramp the sample while the reference remains stable. There is no query for this setting. Ramping both the sample and reference at different rates or to different target temperatures (see below) is not possible.

The ramp rate (°C/min) is calculated as  $(RT / 100) / (RS / 60)$ . Ramp rates corresponding to selected RS and RT pairs are given in the table below.

°C/min	0.05	0.1	0.2	0.5	1	2	5	10
RS	12	12	6	6	3	3	3	3
RT	1	2	2	5	5	10	25	50

Note: For the higher ramp settings, the observed rate may be lower than that calculated from RT and RS or it may be nonlinear over part of the temperature range because the maximum possible rate of heating or cooling is limited (and dependent on the temperature).

To Ramp the temperature:

1. equilibrate at the starting temperature,
2. set the time (RS) and temperature (RT) increments,
3. set a new target temperature.

The new target may be above or below the current temperature and, as soon as it is set, the ramp will begin, up or down, to that new target.

After reaching the target the controller will hold at that temperature. At any time RS and RT may be reset and a new ramp initiated by setting another target temperature.

Once you are done, terminate ramping by resetting both RS and RT to 0. Otherwise, setting a new target temperature later will initiate a ramp to that target temperature.

---

## 12. Cell Changing

**The commands in this class will have no effect unless the sample holder has multiple positions. This includes all TC 425 controllers (4 positions with buttons on the controller that can be used to change the position manually) and some TC 125 controllers (more than 4 positions and no buttons, so software must be used to control the position setting).**

- [F2 DI]               Device initialize: move to home position.  
[F2 PI]               Device initialize: move to home position and reply when done.  
..... [F2 OK]       Device is finished moving.  
[F2 DL 3]             Device locate: move to position 3. (Device must be initialized prior to using this command.)  
[F2 PL 6]             Device locate: move to position 6 and reply when done.  
..... [F2 DL 6]       Device is now in position 6.  
[F2 ?]                Report status of device.

..... [F2 OK]	Device is ready to accept commands.
..... [F2 BUSY]	Device is busy running commands.
[F2 PL ?]	What is the device location (position)?
..... [F2 DL 2]	Device is in position 2. (If reply is 0, device is not initialized.)
[F2 DD 2]	Set speed to 2 (acceptable range 2-250 with 2 being fast, 250 being slow).
[F2 DD ?]	What is the current device speed?
..... [F2 DD 2]	Device is set to speed setting 2. If reply is 0, then the firmware default value (which depends on the sample holder) is being used.

---

### 13. Reference Cuvette (TC 225 only)

[R1 ... ]

To control the temperature of the reference cuvette of a Dual Temperature Controller, use any commands in classes 3-8, substituting R1 for F1. There are no corresponding [R1 ... ] commands for classes 9 – 11.

If you wish to ramp the temperature of the reference and sample cuvettes together, please note the linking command [F1 TL +] in command class 11.