

Instruction Manual

qpod[®]

Temperature-Controlled Sample Compartment for Fiber Optic Spectroscopy



Table of Contents

qpod Temperature-Controlled Sample Compartment for Fiber Optic Spectroscopy	2
Overview	2
Items Included with Your Purchase	2
System Setup	3
Optics	3
System Operation	5
Error Conditions	6
Serial Control for the qpod	6
Temperature Specifications	6
Other Specifications	7
Optical slits provided with the qpod	8
Appendix 1: Computer Control	9
Appendix 2: The QNW Serial Control Program	13
Appendix 3: Example Script: Temperature Ramping	16
Temperature Performance Certificate	20

qpod Temperature-Controlled Sample Compartment for Fiber Optic Spectroscopy

Manual Version 05-05-09

OVERVIEW

The **qpod** is a complete sample compartment for fiber optic spectroscopy, including a Peltier-controlled cuvette holder with magnetic stirring, and fused silica lens systems with SMA fiber optic connectors.

You have purchased one of three **qpod** packages. The **CUV-qpod-ABSKIT** provides collimating optics to pass light straight through for absorbance, transmittance or turbidity measurements. The **CUV-qpod-FLKIT** provides imaging lens systems for excitation and detection of fluorescence emission at right angles. The **CUV-qpod-MPKIT** is a multipurpose kit with a combination of optics that may be used for either absorbance or fluorescence measurements.

The **qpod** is constructed of a single molded housing. A Peltier-controlled cuvette holder in the center provides temperature control and variable speed magnetic stirring, and holds optical slits for limiting light access to the cuvette as needed. A dry gas purge may be used to minimize condensation when working at low temperatures. SMA fiber optic connections and high quality fused silica optics may be inserted in different combinations into optical ports in the walls surrounding the cuvette holder. Accessories such as polarizers and filter holders may be inserted in the light paths. Spherical mirrors may be used to enhance excitation or emitted light. All optics provide focusing and position adjustments for maximizing signal throughput.

ITEMS INCLUDED WITH YOUR PURCHASE

A. qpod and Optics Package

1. **qpod** with lid and cap

2. one of three optical kits:
 - ABSKIT** - optics for absorbance or transmission measurements:
 - a. 2 QCL-UV collimating lenses
 - FLKIT** - optics for fluorescence measurements:
 - a. 2 QIL-UV imaging lenses
 - b. 2 QMP mirror plugs
 - MPKIT** - multipurpose kit:
 - a. 2 QCL-UV collimating lenses
 - b. 2 QIL-UV imaging lenses
 - c. 2 QMP mirror plugs
3. **plastic utility box** containing:
 - a. 5/64-inch hex driver
 - b. set of optical slits
 - c. stir bar
 - d. 2 blanks for unused optical ports

B. Temperature Controller

1. **TC 125** Temperature Controller
2. **qpod** manual
3. **electrical cable** to connect the TC125 to the **qpod**
4. **power cord** for the Temperature Controller
5. **If you ordered** the **SER 2.2** option, you will also find:
 - a. CD with the program Serial Control V2.2
 - b. USB cable to connect the Temperature Controller to your computer

C. BATH 100

1. **submersible pump**
2. **plastic bucket**
3. **a length of tubing**

D. Optional Items - Any optical components such as polarizers or optical filter holders

SYSTEM SETUP

1. If desired, fasten the **qpod** down to a table or optical breadboard. The holes in the corners of the base are located and sized such that it will attach via ¼-20 screws to a table with 1-inch centers or with M-6 screws to a table with 25 mm centers.
2. Supply circulating water to the Peltier unit. Attach tubing from the submersible pump to either one of the water hose barbs on the **qpod**. Attach another piece of tubing from the **qpod** back to the bucket. Put water in the bucket, turn on the pump by plugging it into an outlet and check to be sure that water is flowing back into the bucket. Check for leaks. Unplug the pump until you have completed the remainder of the system set up.
3. If you plan to work at low temperatures, connect a source of dry gas (typically nitrogen) using a length of tubing with 1/8" (3mm) inside diameter, to the hose barb labeled "gas" on the side of the **qpod**. A flow of gas must be used to prevent condensation on the faces of the cuvette when working below the dew point temperature. Set the dry gas flow rate to 50 - 200 cc/min.
4. Attach the electrical cable between the TC 125 and the **qpod**.
5. Attach the power cord to the back of the temperature controller and plug it in.
6. Insert optics as described in the next section.

OPTICS

There are two basic optical configurations for the **qpod**: one to measure **absorbance** and the other to measure **fluorescence**.

Optics to measure absorbance

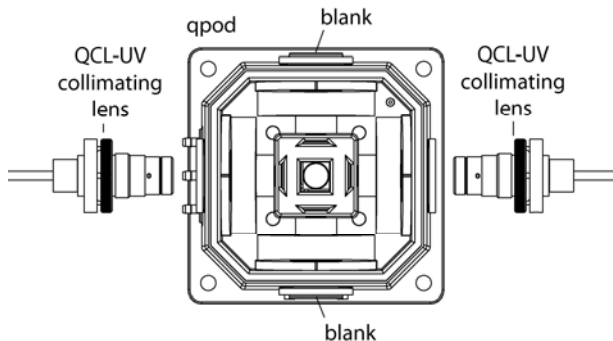

Figure 1 - Absorbance configuration

As shown in **Figure 1**, to set the **qpod** up for absorbance measurements insert collimating lens on any two opposite sides of the **qpod**. Put black plastic blanks from the **qpod** accessory kit in the other two optical ports. One lens collimates the output from the source fiber into a beam about 5 mm in diameter. The beam passes through the sample and is then focused on the collection fiber. A collimating lens assembly contains a single 6 mm diameter, 12 mm focal length, broadband AR-coated, fused silica lens whose principal point is located 12 mm from the end of the fiber.

Optics to measure fluorescence

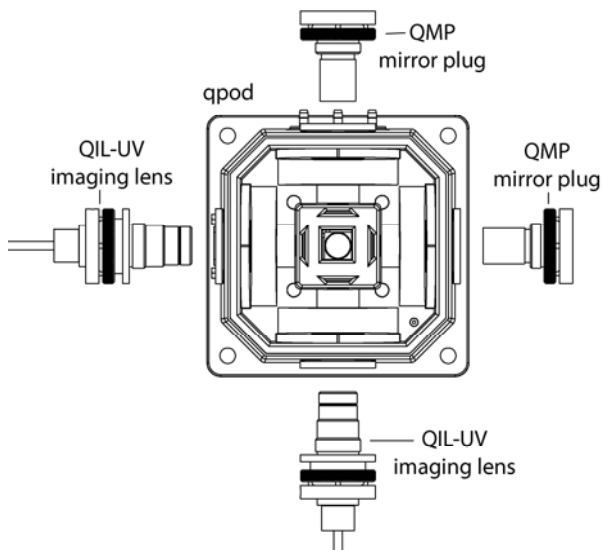

Figure 2.

As shown in **Figure 2**, to set the **qpod** up for fluorescence measurements insert an imaging lens to focus light from a source fiber into the center of the sample cuvette. Place another imaging lens at 90° to the source lens images the illuminated volume onto a collection fiber. To enhance collection efficiency, spherical mirrors may be placed on the remaining positions of the **qpod**. One opposite the excitation fiber focuses the excitation source back through the sample and another opposite the collection lens focuses extra emitted light back through the sample to roughly double the amount of emitted light collected.

An imaging lens assembly contains two ½-inch diameter, 30 mm focal length, broadband AR-coated fused silica lenses. The principal point of one lens is located 30 mm from the fiber and the principal point of the second lens is located 30 mm from the center of the cuvette. Thus the imaging lens pair creates an image of the fiber end, without magnification, in the center of the cuvette, or images the illuminated volume on a collection fiber.

Inserting a lens into the qpod

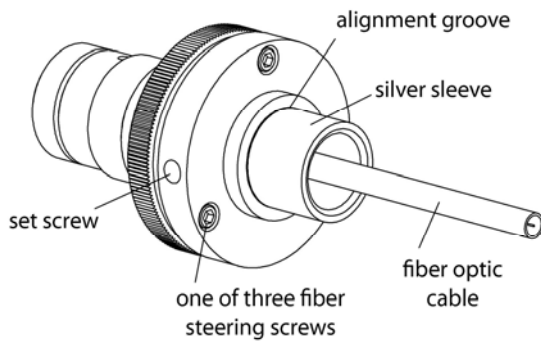

Figure 3 - Components of a lens assembly

1. Use the 5/64-inch hex screwdriver from the **qpod** accessory kit to loosen the set screw (**Figure 3**).
2. Remove the silver sleeve with a black end piece from the lens assembly. Set it aside.

3. Screw the empty optical assembly all the way into the appropriate position in the **qpod**. If you are using an accessory component such as a filter holder or polarizer. First place the accessory in the **qpod**. As you screw in the empty lens assembly the accessory will fit over its end and then snap into place.
4. Look for the location of the set screw. If it is in a difficult position to reach, remove the three fiber steering screws, rotate the end of the optical assembly until the set screw is accessible, and reattach the alignment assembly so the screw is more available. The steering screws compress an o-ring, permitting fine alignment of the end of the fiber relative to the lens.

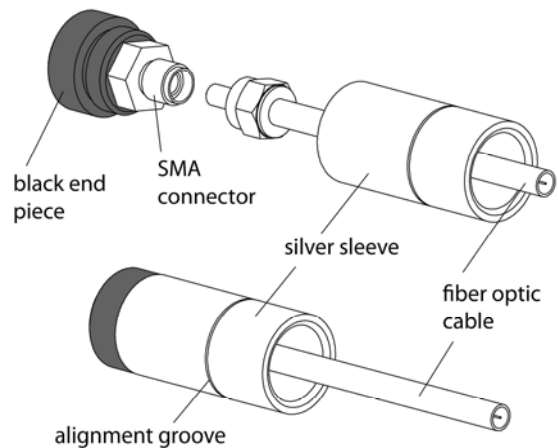

Figure 4 - Attaching the fiber optic to the SMA connector

5. Now, unscrew the silver sleeve from the black end piece revealing the SMA connector (**Figure 4**).
6. Slide the silver sleeve over the end of the fiber optic connector and cable, leaving the threaded end toward the end of the cable.
7. Attach the fiber optic cable to the SMA connector.

8. Holding the black end piece, screw the silver sleeve back into place.
9. Insert the SMA connector and silver sleeve into the hole in the optical assembly. For a first adjustment, insert the assembly until the alignment groove is even with the face of the lens assembly. Later, you can optimize the signal intensity by sliding the SMA connector and silver sleeve in deeper.

SYSTEM OPERATION

1. Use a liquid sample of at least 1.5 ml and place it in a standard 1 x 1-cm square cuvette. Place the cuvette in the cuvette holder in the center of the **qpod**. Standard microcuvettes may also be used for smaller volumes. The **qpod** is designed to hold microcuvettes in which the “z” dimension (distance between the bottom of the cuvette and the optical center line) is 8.5 mm.

Note: The **qpod** is intended to hold a cuvette with a standard wall thickness of 1.25 mm and total width of 12.5 mm. Cuvettes with unusually thick walls will not properly fit and may damage the holder.

2. If needed, place the magnetic stir bar in the cuvette and turn the magnetic stirrer knob located on the front of the temperature control until the desired speed is reached.
3. To monitor the temperature inside the cuvette, plug a standard Series 400 or Series 500 thermistor probe into the ¼ - inch phone plug jack located in the back of the temperature controller. Standard Series 400 and 500 thermistor probes are available from a number of suppliers. We favor the model ON-402-PP by Omega (omega.com). Thread the probe through the split rubber plug in the **qpod** cap and place it in the cuvette out of the way of the light.
4. Provide a source of light and a detector. You may maximize the signal by adjustments of the three fiber steering screws, making small

movements of the position of the fiber end relative to the lens, and by loosening the set screw to insert the silver sleeve deeper into the lens assembly. Inserting the silver sleeve further into lens assembly moves the end of the fiber closer to the lens, altering the focus of the light. This adjustment is most important at UV wavelengths.

5. Use the optical slits or blanks (provided in the **qpod** accessory kit) around the cuvette in a manner that correctly limits the excitation and emission light.
6. Put the cover and cap on the **qpod**.
7. Turn on the submersible pump by plugging it in. Cooling water flows through a heat exchanger and removes heat from the thermoelectric device when the temperature of the holder is being lowered. Insufficient flow will allow the heat exchanger temperature to rise. If the temperature of the heat exchanger exceeds a certain cutoff value, temperature control will be automatically shut down to protect the holder.

Cooler circulating water can result in improved performance of the cuvette holder at low temperatures, whereas warmer water can improve performance at very high temperatures. **Do not use warm or room temperature water when setting temperatures near room temperature, as temperature instabilities are likely to arise.** Cool the circulating water by the addition of ice to the bucket.

A circulating bath may be used to provide circulating fluid to the **qpod**. Using such a bath, temperatures well below the specified -30 °C lowest temperature may be readily achieved. Contact us for suggestions on how to achieve very low temperatures.

8. Turn on the temperature controller using the switch located on the left side of the rear panel of the temperature control unit. When the TC

125 is turned on, the display briefly indicates the software version number running in the microcontroller and an ID number that identifies the kind of sample holder that is being controlled (see further information in Appendix 1).

9. Set the target temperature using the up and down arrows. The normal temperature range is -30 °C to +105 °C. Contact us for suggestions if you would like to work at temperatures lower than -30 °C.

If there is no external probe plugged into the rear of the unit, the TC 125 displays the *holder* temperature, the precise temperature measured in the metal body of the cuvette holder, and the *target* temperature, the temperature that the controller is attempting to achieve. The *holder* temperature sensor is located at cuvette window height on one of the corners of the cuvette tower. If a probe is being used, then the controller displays instead the *holder* temperature and the *probe* temperature. To see the *target* temperature, briefly touch either the up or down arrow button.

10. To begin controlling the temperature, depress the run/stop button located to the left of the display. Depressing the run/stop button a second time will turn temperature control off. When the sample holder approaches the target temperature, the red light located on the upper left corner of the front panel of the temperature controller, will flash slowly. When the sample holder reaches and holds within ± 0.02 °C of the target temperature, the red light will remain constant.
11. If you purchased the Serial Control option, you may load the software at any time and begin using it. Instructions are found in the Help system.
12. After measurements are completed, depress the run/stop button to stop temperature control, and turn off power and water sources.

ERROR CONDITIONS

Rapid flashing of the red light indicates an error condition. The common errors that will display are: **Error conditions E5, E6 and E7 – Check Cables.** One or more of these error conditions is likely to arise if the electrical connection between the Temperature Controller and the **qpod** is not secure. In this case, turn off the power to the unit, check the cable, turn on the power, and resume work.

Error condition E8 – Low water flow. This error condition indicates that the heat exchanger on the thermoelectric cooler is getting too warm. This heating will occur if insufficient cooling water is flowing into the device. Error condition E8 will automatically shut down temperature control to prevent damage to the unit. If this occurs, improve cooling water flow and re-start temperature control.

If correcting these problems does not solve the error messaging, or if other errors are displayed, contact Quantum Northwest by calling (509) 624-9290 or by e-mailing us at quantum@qnw.com.

TEMPERATURE SPECIFICATIONS

Temperature capabilities of Quantum Northwest cuvette holders depend on the product you have and the conditions under which it is operated.

Maximum Temperature. The **qpod** system is limited to temperatures below 105 °C. A higher target temperature cannot be set since such temperatures may damage internal components. This maximum can be attained with coolant at 15 °C or above.

Minimum Temperature. While the **qpod** system is capable of operation as low as -40 °C, the minimum useful temperature depends on the conditions under which it is used.

1. Without special conditions, using room temperature coolant, the minimum is the dew point temperature of the air at the location of use (roughly 5 °C). Below the dew point

temperature, condensation on the cuvette windows will interfere with measurements.

2. With a dry gas flow rate of at about 200 cc/min into the gas inlet of the sample holder, the minimum temperature is about -10 °C. Below -10 °C there is a risk of frosting of the cuvette surfaces.
3. When using ice water as coolant and dry gas flow, the minimum temperature is about -25 °C. In high humidity environments there is increased potential for frost formation even with gas flow.

Probe Temperature Range. The TC 125, TC 225 and TC 425 temperature controllers accept standard 400 and 500 Series thermistor probes. These probes may be obtained from supply companies such as Cole Parmer (coleparmer.com). Standard 400 Series temperature probes will measure the temperature within ± 0.2 °C over the range of 0.0 to 70.0 °C. The probe will operate over the full range of -40 °C to +105 °C, but an individual probe will need to be calibrated by the user outside of the 0.0 to 70.0 °C range. The 500 Series probes are less standardized and may require calibration

by the user. 500 Series probes may be convenient, because they are available in very small diameters.

Other Specifications

Variable speed magnetic stirring is provided primarily to speed up temperature equilibration. Two stir bars are included.

A dry gas purge is provided. The gas travels through the base of the cuvette holder for temperature equilibration and then blows onto the exposed faces of the cuvettes. The gas purge minimizes condensation on the cuvette surfaces. An opaque lid covers the tops of the cuvettes to provide isolation from the ambient environment.

An optional serial interface is available for remote computer control (see Appendices).

Optical access. The **qpod** holds a standard 1 cm square cuvette and precisely maintains its temperature. Access is provided on four sides of the cuvette through optical ports 10 mm wide by 12 mm high.

Appendix 1: Computer Control

With the exception of setting the rate of stirring, all functions of the temperature controller can be managed from a computer, using the command set described below and a program that communicates with the controller through a serial linkage.

If you purchased your unit as a component of a spectrometer from certain manufacturers, this feature may be implemented through traditional RS232 serial connectors on the computer and the controller. In this case they will be connected by a standard 15-pin serial extension cable (male connector on one end and female on the other). No driver installation should be needed.

Otherwise the serial linkage will be established through a USB connection between the computer and the controller. In this case the controller includes electronics which convert the USB connection to a serial communications port. However, for the port to be available to programs on the computer it will be necessary to load driver software. It is important that the driver software be loaded before connecting a USB cable between the controller and the computer. Contact Quantum Northwest for further information.

Some features of the system such as ramping at different rates from one temperature to another are available only through computer control.

Quantum Northwest can provide a control program written specifically for control of all functions of the temperature controller. See Appendix 2 for further information.

The remainder of this section lists the serial commands understood by the temperature controller. For many of the commands the controller returns information in response to the command. All commands and replies are delineated by left and right square brackets ([]). In this document an ellipsis (.....) is used to distinguish replies from commands. Any text sent to the controller not enclosed within brackets will be ignored.

This is the software specification for Version 9.0 of the firmware on Quantum Northwest temperature controllers TC 125, TC 225 and TC 425 issued September 21, 2007. The version number and the ID (see below) are displayed briefly on the display when the temperature controller is turned on.

[command]	purpose of the command (sent to the controller)
.....[reply]	meaning of the reply (received from the controller)

Identify

[F1 ID ?]	What is the ID number of the sample holder being controlled?
.....[F1 ID 31]	Sample holder is a four-position turret with probe capability.

Assigned Identities:

ID =	10	single cuvette holder
	11	single cuvette holder with probe capability
	12	high temperature single cuvette holder
	20	dual cuvette holder
	21	dual cuvette holder with probe capability
	22	dual-controlled titrator
	30	4-position turret
	31	4-position turret with probe capability
	32	6-position linear cell changer

Identity Classes:

- (10 – 19) device using single temperature controller
- (20 – 29) device using dual temperature controller
- (30 – 39) multiple cell changer

Software Version

- [F1 VN ?] What is the version number of the software?
..... [F1 VN 8.0] The controller is operating software version number 8.0.

Stirrer

- [F1 SS +] Turn stirrer on (stir rate must be set manually).
[F1 SS -] Turn stirrer off.

Temperature Control

- [F1 TC +] Turn temperature control on.
[F1 TC -] Turn temperature control off.

Target Temperature

- [F1 TT S 23.10] Set target temperature to 23.10 °C.
[F1 TT ?] What is the current target temperature?
..... [F1 TT 71.32] Target temperature is 71.32 °C.
[F1 TT +] Turn on automatic reporting of manual changes to the target temperature
[F1 TT -] Turn off automatic reporting of manual changes to the target temperature

Instrument Status

- [F1 IS ?] What is the current instrument status?
..... [F1 IS 0-+S] Response is four parameters:
 number of unreported errors is 0 (0 to 9)
 stirrer is off (+ is on, - is off)
 temperature control is on (+ is on, - is off)
 temperature is stable (S is stable, C is changing)
[F1 IS +] Automatically report instrument status whenever it changes
 (e.g., due to manual changes at controller)
[F1 IS -] Stop periodic or automatic reports of instrument status.
..... [F1 IS R] The controller has been powered off and back on again.

Current Temperature

- [F1 CT ?] What is the current temperature of the holder?
..... [F1 CT 22.84] The current temperature is 22.84 °C.
[F1 CT +3] Automatically report current temperature every 3 seconds.
[F1 CT -] Stop periodic current temperature reports.
-

Probe Status

[F1 PS ?]	Is there an external temperature probe connected?
.....[F1 PR +]	A probe is connected.
.....[F1 PR -]	No probe is connected.
[F1 PS +]	Enable probe status to be sent automatically when a probe is installed or removed. This is the default.
[F1 PS -]	Disable automatic sending of probe status.
[F1 PT ?]	What is the current probe temperature?
[F1 PT +3]	Automatically report the probe temperature every 3 seconds.
.....[F1 PT 22.3]	The current probe temperature is 22.3 degrees.
.....[F1 PT NA]	Probe temperature is not available.
[F1 PT -]	Stop automatic probe temperature report.
[F1 PA S 0.5]	Automatically report probe temperature every increment of 0.5 degrees during a ramp. (Increment must be a positive value without sign in tenths between 0.1 and 9.9 degrees and will work for ramps going up or down.)
[F1 PA +]	Start automatic reporting of probe temperature every temperature increment.
.....[F1 PT 30.5]	The current probe temperature is 30.5 degrees.
[F1 PA -]	Stop automatic reporting of probe temperature every temperature increment.
[F1 PX +]	Change probe temperature returned to a precision of 0.01 degree.

Error Reporting

[F1 ER ?]	Report the current error. For a more complete description, see "Error Codes" in the help system of the Serial Control Program.
.....[F1 ER -1]	No current error
.....[F1 ER 05]	Cell T out of range (Loose cable? Sensor failure?)
.....[F1 ER 06]	Cell & heat exchanger T out of range (Loose cable?)
.....[F1 ER 07]	Heat exchanger T out of range (Loose cable? Sensor failure?)
.....[F1 ER 08]	Inadequate coolant (check flow). Control has shut down.
.....[F1 ER 09]	Syntax error on a preceding command.
[F1 ER +]	Automatically report errors when they occur
[F1 ER -]	Stop automatic error reports

Ramping

[F1 RS S 3]	Set the time increment to 3 seconds (must be a positive integer).
[F1 RT S 10]	Set the temperature increment to 0.1 °C (a positive integer, units are hundredths of a degree).
[F1 TL +]	Ramp the sample and reference identically (TC 225 dual controller only).
[F1 TL -]	Ramp the sample and reference separately (TC 225 dual controller only).

The ramp rate (°C/min) is calculated as (RT / 100) / (RS / 60). Ramp rates corresponding to selected RS and RT pairs are given in the table below.

°C/min	0.05	0.1	0.2	0.5	1	2	5	10
RS	12	12	6	6	3	3	3	3
RT	1	2	2	5	5	10	25	50

Note: For the higher ramp settings, the observed rate may be lower than that calculated from RT and RS or it may be nonlinear over part of the temperature range because the maximum possible rate of heating or cooling is limited (and dependent on the temperature).

To Ramp the temperature:

1. equilibrate at the starting temperature,
2. set the time (RS) and temperature (RT) increments,
3. set a new target temperature.

The new target may be above or below the current temperature and, as soon as it is set, the ramp will begin, up or down, to that new target.

After reaching the target the controller will hold at that temperature. At any time RS and RT may be reset and a new ramp initiated by setting another target temperature.

Once you are done, terminate ramping by resetting both RS and RT to 0. Otherwise, setting a new target temperature later will initiate a ramp to that target temperature.

Cell Changing

[F2 DI]	Device initialize: move to home position.
[F2 PI]	Device initialize: move to home position and reply when done.
.....[F2 OK]	Device is finished moving.
[F2 DL 3]	Device locate: move to position 3. (Device must be initialized prior to using this command.)
[F2 PL 6]	Device locate: move to position 6 and reply when done.
.....[F2 DL 6]	Device is now in position 6.
[F2 ?]	Report status of device.
.....[F2 OK]	Device is ready to accept commands.
.....[F2 BUSY]	Device is busy running commands.
[F2 PL ?]	What is the device location (position)?
.....[F2 DL 2]	Device is in position 2. (If reply is 0, device is not initialized.)
[F2 DD 2]	Set speed to 2 (acceptable range 2-250 with 2 being fast, 250 being slow).
[F2 DD ?]	What is the current device speed?
.....[F2 DD 2]	Device is set to speed setting 2. (If reply is 0, then internal default value is being used.)

Reference Cuvette

[R1 ...]

To control the temperature of the reference cuvette of a Dual Temperature Controller, use any commands in classes 3-7, substituting R1 for F1. If you wish to ramp the temperature of the reference and sample cuvettes together, please note the linking command [F1 TL +] in command class 10.

Appendix 2: The QNW Serial Control Program

Quantum Northwest can provide a serial control option for use with this system (item number SER 2.3). The option consists of a serial or USB cable and a CD for installation of the necessary drivers and the Windows program *QNW Serial Control*.

In addition to the those functions managed by the touch pads and display on the front of the temperature controller (with the exception of changing the speed of the magnetic stirrer), the QNW Serial Control Program provides the following additional functionality.

1. Enables generation of a temperature ramp at a user specified rate.
2. Maintains records of temperature as a function of time for the sample holder and for the thermistor probe (and also for the reference holder for the dual controller). The time interval between time/temperature entries is determined by the user.
3. Saves the time/temperature records to tab-delimited text files or copies the records to the Windows clipboard.
4. Displays a plot of the time/temperature records singly or together (an example can be found in Appendix 3). The plots can be copied to the Windows clipboard.
5. Has a setting that will notify the user that the holder temperature has been stable for a user specified time. This is useful because the sample temperature always lags behind the holder temperature. This capability is available only if the computer has a speaker.
6. Allows the user to send individual commands or short series of commands to the controller.
7. Permits the user to monitor all communications to and from the controller.
8. Enables the user to send a long series of commands by loading a text file (known as a controller script) that can be easily generated in a text editor such as Windows Notepad.
9. Provides a number of program specific script commands to help manage execution of the script. For example:
 - A command to delay a specified time before executing the next script command.
 - Various commands to wait for specified conditions such as holder temperature stability or the completion of a temperature ramp. Once the condition is satisfied, script execution proceeds to the next command.

The following list includes all of the program specific script commands for QNW Serial Control V2.3.

Delay and Wait commands

[*D #] - Delay # INTERVALS before running the next command. Example: [*D 120] will cause a delay of 120 of the INTERVAL units as defined in the first line of the script (see the example script in Appendix 3 where the second line sets INTERVAL to 0.6 seconds or 0.01 minutes).

[*WRP>=#] - Wait until the ramp parameter exceeds or equals a particular value (# as an integer).

[*WRP<=#] - Wait until the ramp parameter decreases to or below a particular value (# as an integer).

[*WCT>=#] - Wait until the current (holder) temperature exceeds or equals a particular value (# as an integer).

[*WCT<=#] - Wait until the current temperature decreases to or below a particular value (# as an integer).

The current temperature is the temperature of the metal body of the sample cuvette holder.

[*WPT>=#] - Wait until the probe temperature exceeds or equals a particular value (# as an integer).

[*WPT<=#] - Wait until the probe temperature decreases to or below a particular value (# as an integer).

The probe temperature is the reading of the standard 400 series or 500 series probe plugged into the temperature controller. Typically the probe is used to monitor the temperature of the sample in the cuvette.

[*WRT>=#] - Wait until the reference temperature exceeds or equals a particular value (# as an integer).

[*WRT<=#] - Wait until the reference temperature decreases to or below a particular value (# as an integer).

The reference temperature is the temperature of the metal body of the reference cuvette holder (dual controller only).

[*WT #] - This program command will cause the script to Wait until the Temperature is stable before continuing to the next script command in the list. Temperature stability is determined by an algorithm built into the controller. The parameter (#) determines how often the program sends a status query to the controller ([F1 IS ?], see Appendix 1 under Instrument Status). Each time this query is received, the controller returns a status message which includes information as to whether the temperature is still changing or has met the criteria for being stable (controlled).

The time between status queries is the product of the parameter (#) and the script INTERVAL as defined in the first line of the script (see the example script in Appendix 3 where the second line sets INTERVAL to 0.6 seconds or 0.01 minutes).

[*WD #] - This program command will cause the script to Wait for an external Data Acquisition Program (DAP) to set a RESUME flag. The parameter (#) determines how often the program checks to see if the RESUME flag has been set (the time interval is the product of # and the script INTERVAL as defined in the first line of the script – see Appendix 3). The flag is the first letter contained in a specific text file (C:\QNW_SC.DAP). When the *WD command starts, the program opens or creates the file and replaces its contents with the word ACQUIRE. It is assumed that the DAP, provided by the user or by the instrument manufacturer, is running and periodically checking the file contents. When the DAP finds the flag set to ACQUIRE, it must do any data acquisition required then replace the contents of the same file with the word RESUME (actually, any word beginning with a capital R) and close the file. This latter action will then trigger the *WD command to end and the program will continue with the next command in the script.

Beep Control commands

[*BCT +] or **[*BCT-]** - Turn on(+) or off(-) beeping by the computer whenever a sample holder (current) temperature report is received from the controller.

[*BPT +] or **[*BPT-]** - Turn on(+) or off(-) beeping by the computer whenever a probe temperature report is received from the controller.

[*BRT +] or **[*BRT-]** - Turn on(+) or off(-) beeping by the computer whenever a reference holder temperature report is received from the controller.

Warning Control commands

[*E+] or **[*E-]** - When a script is running, attempting to use certain of the buttons or other controls in the main window will cause the appearance of a dialog box asking if you are sure you want to send the associated command (thus changing the series of actions defined by the script). The appearance of this dialog can be avoided at any point in the script by including the program command [*E-]. Alternatively, the appearance of the warning dialog can be reinstated by including [*E+] at any point in the script.

Listing Control commands

[*LIS +] or **[*LIS -]** - Enable (+) or Disable (-) listing of Instrument Status replies during running of a script.

[*LER +] or **[*LER -]** - Enable (+) or Disable (-) listing of Error Message replies during running of a script.

[*LCT +] or **[*LCT -]** - Enable (+) or Disable (-) listing of Current Temperature replies during running of a script.

[*LPT +] or **[*LPT -]** - Enable (+) or Disable (-) listing of Probe Temperature replies during running of a script.

[*LRT +] or **[*LRT -]** - Enable (+) or Disable (-) listing of Reference Temperature replies during running of a script.

These ten program commands can be used to control whether the indicated information, sent from the Serial Controller to the program, are to be listed (displayed) in a script monitoring window while the script is running. Disabling the listings may be useful to make progress of the script clearer since, under some conditions, large numbers of Instrument Status replies and Temperature replies may be generated while the script is running. Disabling affects only the listing of these various replies in the script monitoring window during the running of a script – the temperatures will be included in the time/temperature records.

Miscellaneous commands

[*R] - This program command is used only at the end of a script. It will cause the script to be repeated, starting at the beginning.

[*P] - If the plot window is displayed while a script is running, the data in the plot will not be automatically updated unless a delay (*D) or wait (*W) command is being processed. This program command will cause the plot window to update (replot to show all data collected to that time).

[*CTD] - This command will clear the time/temperature records. In addition, the time will be restarted at zero and a new record of time/temperature will be started.

[*MSG + message] or **[*MSG - message]** - This command will stop execution of the script and present a dialog box containing the second command parameter ("message"). Change this parameter to the wording you want the dialog box to display. The first parameter (+ or -) determines whether the computer beeps (+) or not (-) while the dialog box is visible. When the user clicks the "OK" button the dialog box closes and execution of the script continues.

Appendix 3: Example Script: Temperature Ramping

The following is an example of a script file. Any text that is not enclosed by square brackets ([]) is completely ignored by the script processor, permitting the extensive commenting. When this script was executed by the QNW Serial Control program (described in Appendix 2) the time/temperature data in the plot that follows the script listing was obtained.

```
Controller Script
Interval = .6   Set the time interval between commands to .6 seconds.
-----
Initial Setup
-----
[*E-]          Prevent appearance of a warning dialog that may block script
                execution if a main window button or control is used.
[F1 PX +]      Display probe temperature to 0.01 °C precision.
[F1 TT S 10.00] Set Target Temperature to 10 °C.
[F1 TC +]      Turn on Temperature Control.
[F1 CT +30]    Report current cuvette holder temperature periodically.
[F1 PT +30]    Report probe temperature periodically.
[*LTT -]       Do not list target temperature returns in script window.
[*LCT -]       Do not list current temperature returns in script window.
[*LPT -]       Do not list probe temperature returns in script window.
[*MSG - This script requires pre-equilibration to 10 °C. Click OK when
satisfactory equilibration has been achieved]
                Waits for the user to respond
[*CTD]         Clear time/temperature displays and reset time to zero
[*D=500]       Collect temperatures for 5 minutes.
-----
First Ramp to 40 at 4 °C/min:
-----
[F1 RT S 40]   Set Ramping Temperature Interval to 0.40 °C.
[F1 RS S 6]    Set Ramping Time Interval to 6 seconds.
                Ramping rate will be 4 °C/min (0.4 °C/ 0.1 min).
[F1 PT -]      Stop reporting probe temperature periodically.
[F1 PA +]      Turn on Automatic Probe temperature report
[F1 PA S 2.0]  Set Automatic Probe temperature report to every 2.0 °C.
[*BPT +]      Turn on the option for computer to beep each time a probe
                temperature report is received.
[F1 TT S 40.00] Set Target Temperature to 40 °C, to start ramping process.
[*WRP>=40]    Wait until the ramp parameter reaches 40 °C.
-----
Second Ramp to 45 at 0.2 °C/min:
-----
[F1 RT S 4]    Set Ramping Temperature Interval to .04 °C.
[F1 RS S 12]   Set Ramping Time Interval to 12 seconds.
                Ramping rate will be 0.2 °C/min (0.04 °C/ 0.2 min).
[F1 PA S 0.5]  Set Automatic Probe temperature report to every 0.5 °C.
[F1 TT S 45.00] Set Target Temperature to 45 °C to start ramping process.
[*WRP>=45]    Wait until the ramp parameter reaches 45 °C.
[*D 200]      Wait 2 minutes for probe temperature to catch up.
```

Third Ramp to 80:

[F1 RT S 40] Set Ramping Temperature Interval to .40 °C
[F1 RS S 6] Set Ramping Time Interval to 6 seconds
Ramping rate will be 4 °C/min.

[F1 PA S 2.0] Set Automatic Probe temperature report to every 2.0 °C.
[F1 TT S 80.00] Set Target Temperature to 80 °C to start ramping process.
[*WRP>=80] Wait until the ramp parameter reaches 80 °C.
[*D 300] Wait 3 minutes to allow the probe temperature to catch up
[F1 PA -] Stop automatic probe temperature reporting
[F1 PT +30] Start periodic probe temperature reporting
(current temperature reporting is already running)
[*BPT -] Turn off the computer beep each time a probe
temperature report is received.
[*D 800] Wait 8 min to allow temperatures to stabilize.

Ramp back to 20:

[F1 RT S 25] Set Ramping Temperature Interval to .25 °C.
[F1 RS S 6] Set Ramping Time Interval to 6 seconds.
Ramping rate will be 2.5 °C per minute.
[F1 PT -] Stop periodic probe temperature reporting.
[F1 PA +] Turn on Automatic Probe temperature report.
[F1 PA S 5.0] Set Automatic Probe report to every 5.0 °C.
[F1 TT S 20.00] Set Target Temperature to 20 °C to start ramping process.
[*WRP<=20] Wait until the ramp parameter reaches 20 °C.
[*D 300] Hold 3 minutes to allow the probe temperature to catch up.

Clean up

[F1 RT S 0] Stop ramping. (If this is not done, the next target temperature
[F1 RS S 0] that is set will generate a ramp using the previous settings.)
[F1 PA -] Stop automatic probe temperature reporting.
[F1 PT +30] Start periodic probe temperature reporting.
(Current temperature reporting is already running.)
[*D 700] Wait another 7 minutes for final equilibration.
[F1 PT -] Stop periodic probe temperature reporting.
[F1 CT -] Stop periodic sample holder temperature reporting.
[*E+] Enable appearance of a warning dialog if a main window button
or control is used while a script is running.
[F1 PX -] Reset display of probe temperature to 0.1 °C precision.
[*MSG + The multi-ramp script run is complete]
Notify user, with beeping.

The script sets a target temperature of 10 degrees and then turns temperature control on and waits until the user is satisfied with the state of equilibration. During this time the probe temperature is reported every 30 seconds (the sample holder temperature is reported every 30 seconds throughout the run). The script then initiates the first ramp from 10 to 40 degrees at 4 degrees/min with the computer beeping each time a probe temperature is reported at 2 degree intervals. The second ramp from 40 to 45 degrees is slower (0.2 degrees/min), with the computer beeping every 0.5 degrees (to provide more information over a critical range of temperatures). The third ramp takes the temperature quickly to 80 degrees, again with beeping at 2 degree

intervals. At this point beeping is stopped and an 8 minute delay of script execution allows time for equilibration at 80 degrees; the probe temperature is reported every 30 seconds. The final ramp is down to 20 degrees at 2.5 degrees/min with probe temperature reports every 5 degrees. This is followed by a 7 minute delay for equilibration with automatic probe temperature reports every 30 seconds. Figure 1 shows a typical example of the sample holder and probe temperatures as a function of time.

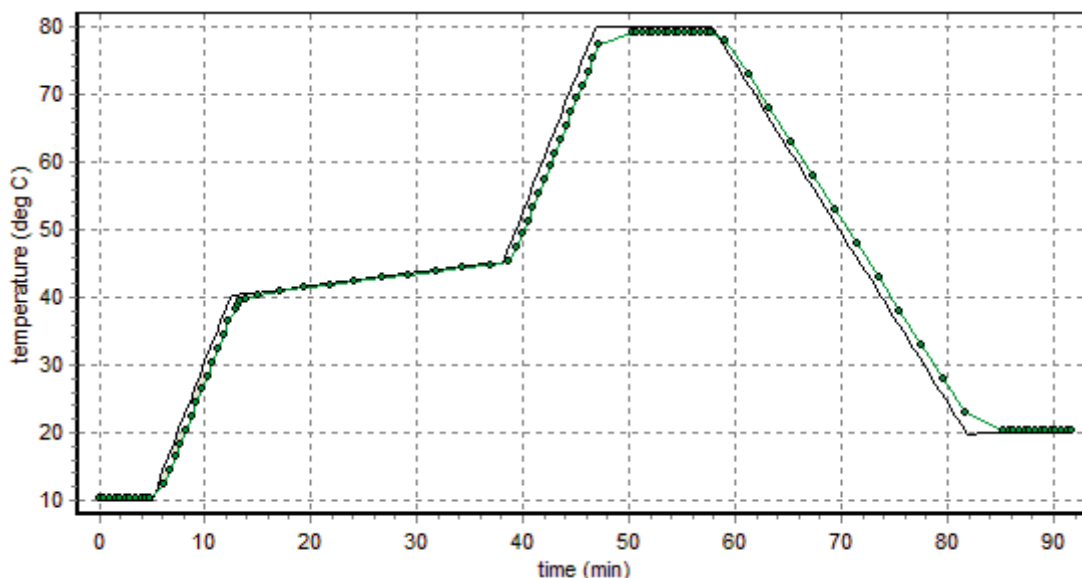

Actual data obtained by running the example script in the QNW Serial Control Program (V2.3). The sample holder temperatures are plotted as a solid line without tokens; the probe temperatures are shown as filled circles connected by a line.

This multi-ramp script would be useful if a researcher were monitoring fluorescence intensity or absorbance of a sample showing a sharp melting transition near 42 °C. By recording the time and signal amplitude each time the probe temperature was reported (each time the computer beeped, between 5 min and 50 min in Figure 1) and correlating those time/amplitude pairs with the time/temperature pairs reported by the QNW Serial Control program, a plot of signal amplitude vs time could be generated. The plot below is a simulation of such a result.

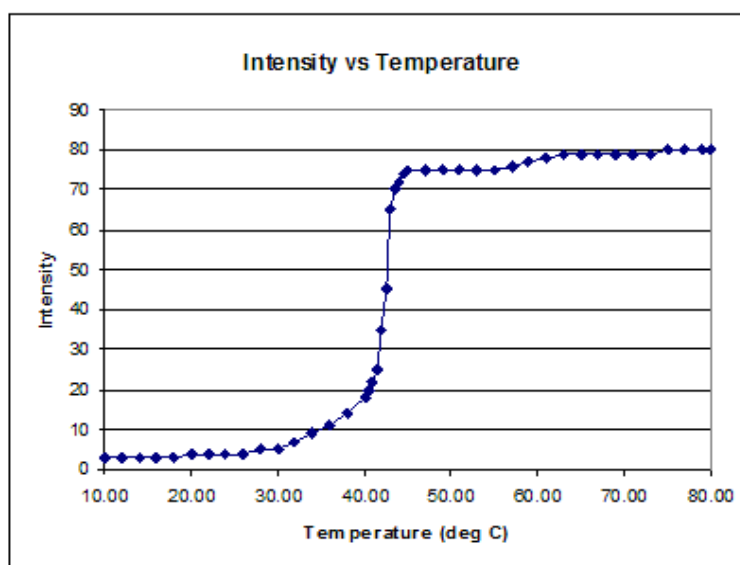

Figure 2. Simulated melting data that might be measured with the example multiple ramp script

Of course, it would be optimal if the sample temperature and the measured parameter could be automatically obtained simultaneously. However, that requires that temperature monitoring and parameter acquisition be done by the same program. Lacking that, then one would like to be able to acquire temperature and parameter data at the same time interval with both acquisition processes started at as close to the same time as possible.

An example of this latter procedure is given in Figure 3 which shows experimental data obtained for the melting transition of the synthetic alternating copolymer of deoxyadenosine and deoxythymidine, poly(dA-dT) using a simple temperature ramp script. The absorbance data were obtained using an Ocean Optics fiber-optic spectrometer, light source and software in combination with a QNW **qpod**[®] fiber-optic sample holder and the QNW Serial Control program. The temperature ramp and absorbance data collections were started “simultaneously” using a timing interval of 0.1 minute.

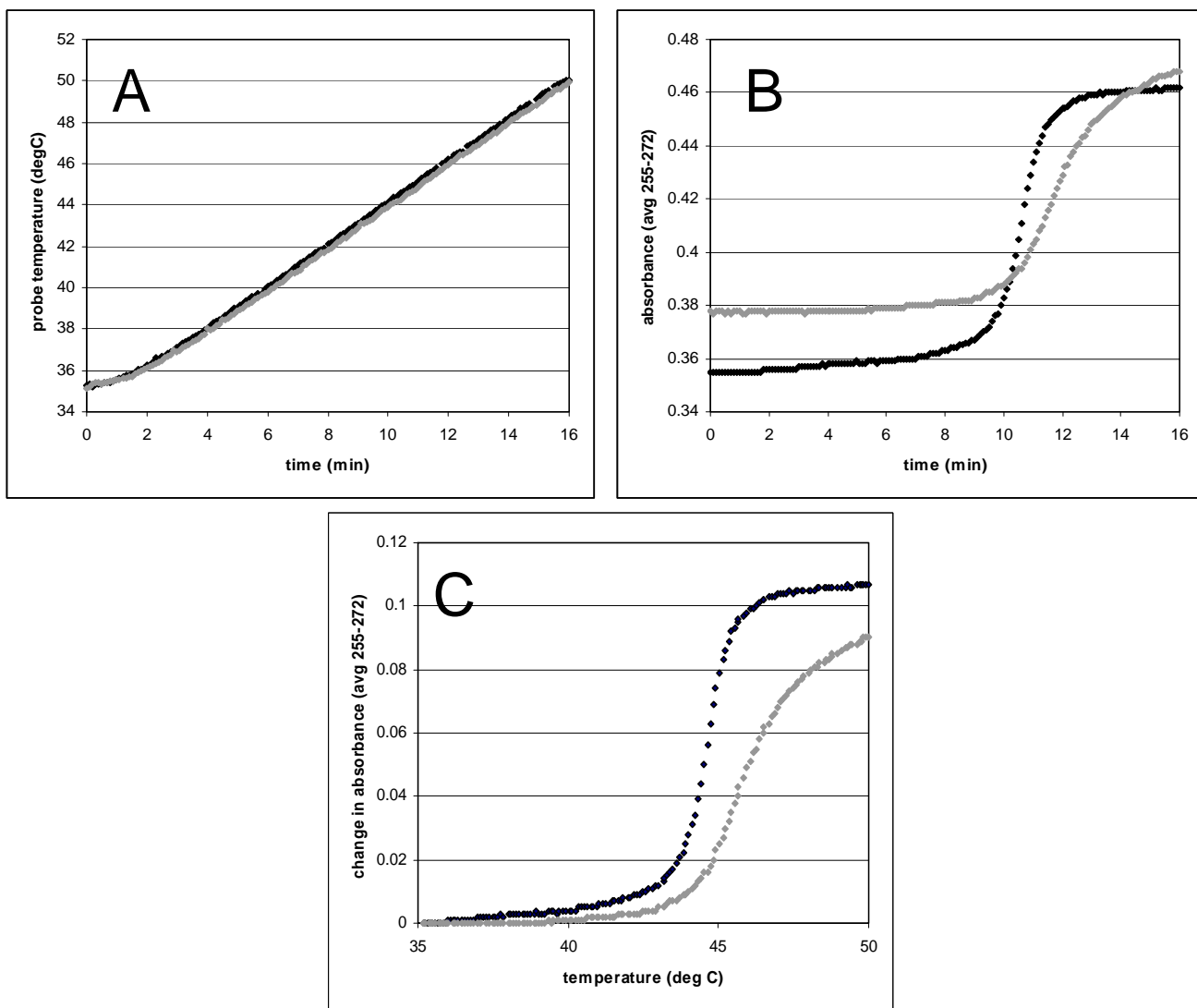

Figure 3. Experimental data obtained for the melting transition of the synthetic alternating copolymer of deoxyadenosine and deoxythymidine, poly(dA-dT) using a linear temperature ramp. Data are shown for the copolymer alone (black) and for the copolymer in the presence of ethidium (gray). Panel A shows the temperature as a function of time. Panel B shows the average absorbance as a function of time. Panel C combines the data in A and B to show the change in the average absorbance as a function of temperature.