

Instruction Manual

TWIN 100™

Temperature-Controlled Twin Cuvette Holder for the
Olis DW-2000



Table of Contents

TWIN 100™ Temperature-Controlled Twin Cuvette Holder for the Olis DW-2000	2
System Setup	2
System Operation	3
Error Conditions	4
Temperature Specifications	4
Other Specifications	5
Appendix: Serial Communications for Quantum Northwest Temperature Controllers	6
Temperature Performance Certificate	11

TWIN 100™ Temperature-Controlled Twin Cuvette Holder for the Olis DW-2000

Manual Version 07-13-11

The TWIN 100™ is a thermoelectric temperature-controlled twin cuvette holder. Rapid and precise temperature changes may be made throughout the range of -25 to +105 °C. (Lower temperatures may be obtained under special conditions.) Variable speed magnetic stirring is provided under both cuvettes as well as dry gas purge on the four exposed cuvette windows. An opaque cover is provided to permit control of the gaseous environment above the cuvettes and to prevent light leakage into the spectrometer. A variety of optical slits are provided to limit transmitted light. Each TWIN 100™ is provided with the TC 125 Temperature Controller, a microprocessor-based controller using a modified PID algorithm.

SYSTEM SETUP

1. Using the 15-pin, VGA-type cable provided, connect the cuvette holder to the back of the temperature controller.
2. Use a length of tubing with 1/8" (3mm) inside diameter such as the vinyl tubing provided to connect a water source to the water connections on the cuvette holder. Flow direction is not important.
3. Set and maintain a cooling water flow rate of about 200 - 300 ml per minute. This flow should require a pressure of approximately 3 - 5 psi (0.2 - 0.3 bar). If a circulating bath is used as the water source, it may not be possible to maintain this flow rate. However, a slower rate will likely be adequate for low temperature work, if pre-cooled circulating water is used.

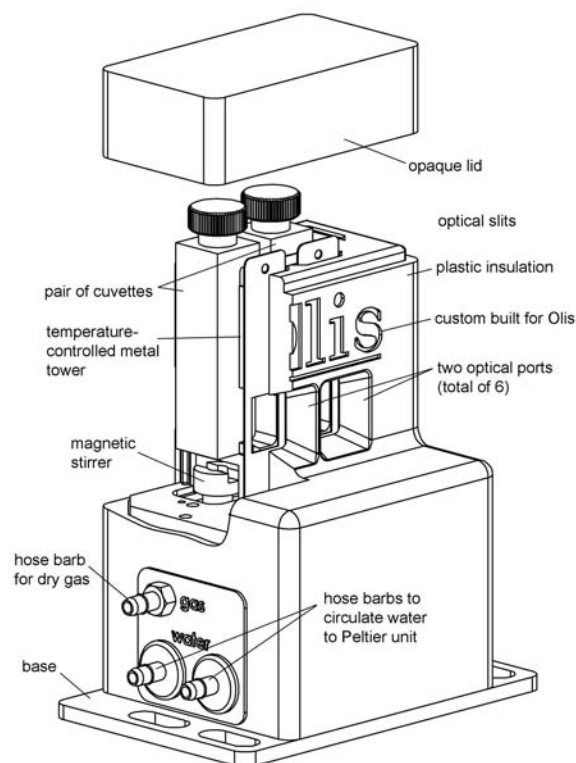

Figure 1.

4. If needed, connect a source of dry gas (typically dry nitrogen) using a length of tubing with 1/8" (3mm) inside diameter, to the hose barb labeled "gas" on the side of the TWIN 100™. A flow of gas must be used to prevent condensation on the faces of the cuvette when working below the dew point temperature. Set the dry gas flow rate to 50 - 200 cc/min.
5. Connect the Temperature Controller to a power source using the electrical cord provided.

SYSTEM OPERATION

1. Turn on the power to the TWIN 100™ system using the switch located on the left side of the rear panel of the temperature control unit. When the TC 125 is turned on, the display briefly indicates the software version number running in the microcontroller and an ID number that identifies the kind of sample holder that is being controlled (see further information in Appendix 1).

Do not exceed an input water pressure of 25 psi (1.7 bar), as damage may occur inside the TWIN 100™.

2. Set and maintain a cooling water flow rate of about 200 - 300 ml per minute. This flow should require a pressure of approximately 3 - 5 psi (0.2 - 0.3 bar).

Cooling water flows through a heat exchanger and removes heat from the thermoelectric device when the temperature of the holder is being lowered. Insufficient flow will allow the heat exchanger temperature to rise. If the temperature of the heat exchanger exceeds a certain cutoff value, temperature control will be automatically shut down to protect the holder.

Cooler circulating water can result in improved performance of the cuvette holder at low temperatures, whereas warmer water can improve performance at very high temperatures. For temperatures below about -25 °C, we recommend 50% methanol-water at a temperature within about 25 to 30 °C of the lowest temperature to be used. We do not recommend ethylene glycol mixtures for low temperature work, because its high viscosity reduces flow rates. **Do not use warm or room temperature water when setting temperatures near room temperature, as temperature instabilities are likely to arise.**

3. Use a liquid samples of at least 1.5 ml and place them in standard 1 x 1-cm square absorbance cuvettes. Standard microcuvettes may also be used

for smaller volumes. The TWIN 100™ is designed to hold microcuvettes in which the “z” dimension (distance between the bottom of the cuvette and the optical center line) is 8.5 mm.

Note: The TWIN 100™ is intended to hold a cuvette with a standard wall thickness of 1.25 mm and total width of 12.5 mm. Cuvettes with unusually thick walls will not properly fit and may damage the holder. Also, unusually short cuvettes will be difficult to remove after being pushed all of the way to the bottom of the holder.

4. Place the cuvettes in the sample holder.

5. Use the provided optical slits or blanks around the cuvette in a manner that correctly limits the excitation and emission light.

6. If needed, place magnetic stir bars in the cuvettes and turn the magnetic stirrer knob located on the front of the temperature control until the desired speed is reached.

7. Place the plastic cover over the cuvette holder.

8. To monitor the temperature inside the cuvette, simply plug a standard Series 400 or Series 500 thermistor probe into the ¼ - inch phone plug jack located in the back of the temperature controller. Thread the probe through the hole in the plastic cover, into the cuvette, and down into a position in the solution out of the way of the beam and the magnetic stir bar. The controller will sense the presence of the probe and display the measured temperature. This thermometer function is calibrated against a Series 400 probe and will have the same specifications typical of these probes. If the accurate temperature is needed, then the probe should be calibrated for use in your experiment. These standard probes are manufactured by Yellow Springs Instrument Company or Digi-Sense, and are readily available through common laboratory suppliers.

9. Set the target temperature using the up/down buttons located to the right of the display window.

If there is no external probe plugged into the rear of the unit, the TC 125 displays the *holder* temperature, the precise temperature measured in the metal body of the cuvette holder, and the *target* temperature, the temperature that the controller is attempting to achieve. The *holder* temperature sensor is located at cuvette window height on one of the corners of the cuvette tower. If a probe is being used, then the controller displays instead the *holder* temperature and the *probe* temperature. To see the *target* temperature, briefly touch either the up or down arrow button.

11. To begin controlling the temperature, depress the run/stop button located to the left of the display. Depressing the run/stop button a second time will turn temperature control off.

12. When the sample holder approaches the target temperature, the red light located on the upper left corner of the front panel of the temperature controller, will flash slowly.

13. When the sample holder reaches and remains within ± 0.02 °C of the target temperature, the red light will remain constant.

14. After measurements are completed, depress the run/stop button to stop temperature control, and turn off power and water sources.

ERROR CONDITIONS

Rapid flashing of the red light indicates an error condition. The common errors that will display are:

Error conditions E5, E6 and E7 – Check Cables.

One or more of these error conditions is likely to arise if the electrical connection between the Temperature Controller and the TWIN 100™ is not secure. In this case, turn off the power to the unit,

check the cable, turn on the power, and resume work.

Error condition E8 – Low water flow. This error condition indicates that the heat exchanger on the thermoelectric cooler is getting too warm. This heating will occur if insufficient cooling water is flowing into the device. Error condition E8 will automatically shut down temperature control to prevent damage to the unit. If this occurs, improve cooling water flow and re-start temperature control.

If correcting these problems does not solve the error messaging, or if other errors are displayed, contact Quantum Northwest by calling (509) 624-9290 or by e-mailing us at quantum@qnw.com.

TEMPERATURE SPECIFICATIONS

Maximum Temperature. The TWIN 100 system is limited to temperatures below 105 °C. A higher target temperature cannot be set since such temperatures may damage internal components. This maximum can be attained with coolant at 15 °C or above.

Minimum Temperature. While the TWIN 100 system is capable of operation as low as -40 °C, the minimum useful temperature depends on the conditions under which it is used.

1. Without special conditions, using room temperature coolant, the minimum is the dew point temperature of the air at the location of use (roughly 5 °C). Below the dew point temperature, condensation on the cuvette windows will interfere with measurements.
2. With a dry gas flow rate of at about 200 cc/min into the gas inlet of the sample holder, the minimum temperature is about -10 °C. Below -10 °C there is a risk of frosting of the cuvette surfaces.
3. When mounted in an enclosure purged with dry gas and using ice water as coolant, the minimum temperature is about -25 °C. An example of such an enclosure is the sample chamber of some spectrophotometers.

Probe Temperature Range. The TC 125, TC 225 and TC 425 temperature controllers accept standard 400 and 500 Series thermistor probes. These probes may be obtained from supply companies such as Cole Parmer (coleparmer.com). Standard 400 Series temperature probes will measure the temperature within ± 0.2 °C over the range of 0.0 to 70.0 °C. The probe will operate over the full range of -40 °C to +105 °C, but an individual probe will need to be calibrated by the user outside of the 0.0 to 70.0 °C range. The 500 Series probes are less standardized and may require calibration by the user. 500 Series probes may be convenient, because they are available in very small diameters.

Other Specifications

Variable speed magnetic stirring is provided primarily to speed up temperature equilibration. Two stir bars are included.

A dry gas purge is provided. The gas travels through the base of the cuvette holder for temperature equilibration and then blows onto the exposed faces of the cuvettes. The gas purge minimizes condensation on the cuvette surfaces. An opaque lid covers the tops of the cuvettes to provide isolation from the ambient environment.

An optional serial interface is available for remote computer control (see Appendices).

Optical access. The TWIN 100 holds two standard 1 cm square cuvettes and precisely maintains their temperature. Access is provided on the three exposed sides of each cuvette through optical ports 10 mm wide by 12 mm high.

Figure 2. Optical slits provided with the TWIN 100.

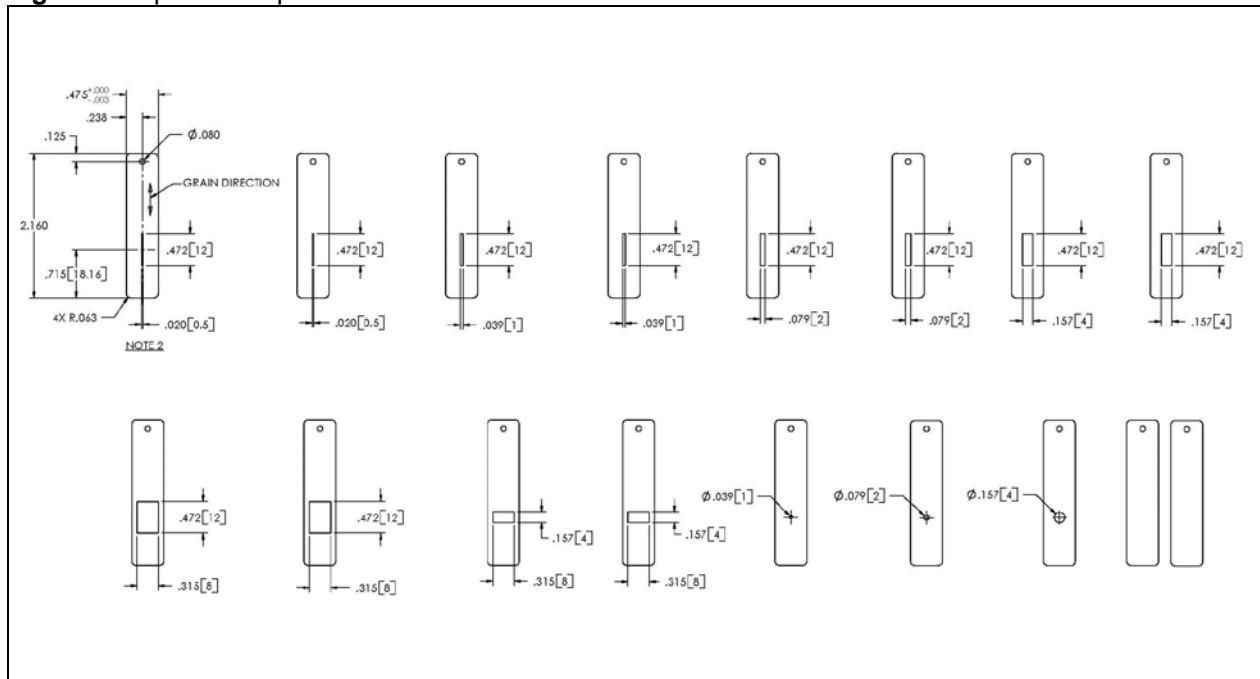

Appendix- Serial Communications for Quantum Northwest Temperature Controllers

07-13-11

This document provides the serial communications protocols for version 9.1 of the firmware on temperature controllers TC 125, TC 225 and TC 425.

The version number and the ID (see below) are shown briefly on the display when the temperature controller is turned on.

With the exception of setting the rate of stirring, all functions of the temperature controller can be managed from a computer, using the command set described below. If you purchased your unit as a component of a spectrometer from certain manufacturers, this feature may be implemented through traditional RS232 serial connectors on the computer and the controller. In this case they will be connected by a standard 15-pin serial extension cable (male connector on one end and female on the other). No driver installation should be needed.

Otherwise the serial linkage will be established through a USB connection between the computer and the controller. In this case the controller includes electronics which convert the USB connection to a serial communications port. However, for the port to be available to programs on the computer it will be necessary to load driver software. It is important that the driver software be loaded before connecting a USB cable between the controller and the computer. Contact Quantum Northwest for further information.

Quantum Northwest can provide a control program written specifically for control of all functions of the temperature controllers. Ask for program T-App.

To communicate with the controller, one must adhere to the conventional notation: 8/N/1.

Baud: 19200
Data Bits: 8
Parity: None
Stop Bit: 1
Flow Control: None

For many of the commands listed below the controller returns information in response to the command. All commands and responses are delineated by left and right square brackets ([]). In this document an ellipsis (.....) is used to distinguish responses from commands. Any text sent to the controller not enclosed within brackets will be ignored.

[command]	purpose of the command (sent to the controller)
.....[reply]	meaning of the reply (received from the controller)

1. Identify

[F1 ID ?] What is the ID number of the sample holder being controlled?
.....[F1 ID 31] Sample holder is a four-position turret with probe capability.

Assigned Identities:

ID = 10 - single cuvette holder
11 - single cuvette holder with probe capability
12 - high temperature single cuvette holder
20 - dual cuvette holder
21 - dual cuvette holder with probe capability
22 - dual-controlled titrator
30 - 4-position turret
31 - 4-position turret with probe capability
32 - 6-position turret (or linear cell) changer

Identity Classes:

- (10 – 13) - single sample holder using a TC 125 controller
- (20 – 22) - two sample holders using a TC 225 controller
- (30 – 31) - multiple cuvette holder using a TC 425 controller
- (32) - multiple cuvette holder using a TC 125 controller,

2. Controller Firmware Version

- [F1 VN ?] What is the version number of the controller firmware?
..... [F1 VN 9.1] The controller is operating firmware version number 9.1.

3. Stirrer

- [F1 SS +] Turn stirrer on. (Stir rate must be set manually.)
[F1 SS -] Turn stirrer off.

4. Temperature Control

- [F1 TC +] Turn temperature control on.
[F1 TC -] Turn temperature control off.

5. Target Temperature

- [F1 TT S 23.10] Set target temperature to 23.10 °C.
[F1 TT ?] What is the current target temperature?
..... [F1 TT 71.32] Target temperature is 71.32 °C.
[F1 TT +] Turn on automatic reporting of manual changes to the target temperature
[F1 TT -] Turn off automatic reporting of manual changes to the target temperature
[F1 MT ?] What is the maximum target temperature allowed
..... [F1 MT 110] The maximum target temperature allowed is 110 °C
[F1 LT ?] What is the lowest target temperature allowed
..... [F1 LT -30] The lowest target temperature allowed is -30 °C

6. Instrument Status

- [F1 IS ?] What is the current instrument status?
..... [F1 IS 0-+S] Response is four parameters:
 number of unreported errors is 0 (0 to 9)
 stirrer is off (+ is on, - is off)
 temperature control is on (+ is on, - is off)
 temperature is stable (S is stable, C is changing)
[F1 IS +] Automatically report instrument status whenever it changes
 (e.g., due to manual changes at controller)
[F1 IS -] Stop periodic or automatic reports of instrument status.
..... [F1 IS R] The controller has been powered off and back on again.

7. Heat Exchanger Temperature

- [F1 HL ?] What is the high temperature limit for the heat exchanger

.....[F1 CT 60] The heat exchanger high temperature limit is 60 °C
[F1 HT ?] What is the current temperature of the heat exchanger?
.....[F1 CT 39] The current heat exchanger temperature is 39 °C.
[F1 HT +3] Automatically report heat exchanger temperature every 3 seconds
[H1 CT -] Stop periodic heat exchanger temperature reports.

8. Current Temperature

[F1 CT ?] What is the current temperature of the holder?
.....[F1 CT 22.84] The current temperature is 22.84 °C.
[F1 CT +3] Automatically report current temperature every 3 seconds.
[F1 CT -] Stop periodic current temperature reports.

9. Probe Status

[F1 PS ?] Is there an external temperature probe connected?
.....[F1 PR +] A probe is connected.
.....[F1 PR -] No probe is connected.
[F1 PS +] Enable probe status to be sent automatically when a probe is installed or removed. This is the default.
[F1 PS -] Disable automatic sending of probe status.
[F1 PT ?] What is the current probe temperature?
[F1 PT +3] Automatically report the probe temperature every 3 seconds.
.....[F1 PT 22.3] The current probe temperature is 22.3 degrees.
.....[F1 PT NA] Probe temperature is not available.
[F1 PT -] Stop automatic probe temperature report.
[F1 PA S 0.5] Set the increment for automatic reporting of the probe temperature to 0.5 degrees during a ramp. (Increment must be positive) without sign in tenths between 0.1 and 9.9 degrees and will work for ramps going up or down.)
[F1 PA +] Start automatic reporting of probe temperature every temperature increment.
.....[F1 PT 30.5] The current probe temperature is 30.5 degrees.
[F1 PA -] Stop automatic reporting of probe temperature every temperature increment.
[F1 PX +] Change probe temperature returned to a precision of 0.01 degree.

10. Error Reporting

[F1 ER ?] Report the current error. For a more complete description, see "Error Codes" in the help system of the Serial Control Program.
.....[F1 ER -1] No current error
.....[F1 ER 05] Cell T out of range (Loose cable? Sensor failure?)
.....[F1 ER 06] Cell & heat exchanger T out of range (Loose cable?)
.....[F1 ER 07] Heat exchanger T out of range (Loose cable? Sensor failure?)
.....[F1 ER 08] Inadequate coolant (check flow). Temperature control has shut down.
.....[F1 ER 09] Syntax error on a preceding command.
[F1 ER +] Automatically report errors when they occur
[F1 ER -] Stop automatic error reports

11. Temperature Ramping

The commands in this class will have an effect only for the TC 225.

- [F1 RS S 3] Set the time increment to 3 seconds (must be a positive integer).
[F1 RT S 10] Set the temperature increment to 0.1 °C (a positive integer, units are hundredths of a degree).
[F1 TL +] Ramp the sample and reference identically.
[F1 TL -] Ramp the sample while the reference remains stable.

The default is to ramp the sample while the reference remains stable. There is no query for this setting. Ramping both the sample and reference at different rates or to different target temperatures (see below) is not possible.

The ramp rate (°C/min) is calculated as $(RT / 100) / (RS / 60)$. Ramp rates corresponding to selected RS and RT pairs are given in the table below.

°C/min	0.05	0.1	0.2	0.5	1	2	5	10
RS	12	12	6	6	3	3	3	3
RT	1	2	2	5	5	10	25	50

Note: For the higher ramp settings, the observed rate may be lower than that calculated from RT and RS or it may be nonlinear over part of the temperature range because the maximum possible rate of heating or cooling is limited (and dependent on the temperature).

To Ramp the temperature:

1. equilibrate at the starting temperature,
2. set the time (RS) and temperature (RT) increments,
3. set a new target temperature.

The new target may be above or below the current temperature and, as soon as it is set, the ramp will begin, up or down, to that new target.

After reaching the target the controller will hold at that temperature. At any time RS and RT may be reset and a new ramp initiated by setting another target temperature.

Once you are done, terminate ramping by resetting both RS and RT to 0. Otherwise, setting a new target temperature later will initiate a ramp to that target temperature.

12. Cell Changing

The commands in this class will have no effect unless the sample holder has multiple positions. This includes all TC 425 controllers (4 positions with buttons on the controller that can be used to change the position manually) and some TC 125 controllers (more than 4 positions and no buttons, so software must be used to control the position setting).

- [F2 DI] Device initialize: move to home position.
[F2 PI] Device initialize: move to home position and reply when done.
..... [F2 OK] Device is finished moving.
[F2 DL 3] Device locate: move to position 3. (Device must be initialized prior to using this command.)
[F2 PL 6] Device locate: move to position 6 and reply when done.
..... [F2 DL 6] Device is now in position 6.
[F2 ?] Report status of device.

.....[F2 OK] Device is ready to accept commands.
.....[F2 BUSY] Device is busy running commands.
[F2 PL ?] What is the device location (position)?
.....[F2 DL 2] Device is in position 2. (If reply is 0, device is not initialized.)
[F2 DD 2] Set speed to 2 (acceptable range 2-250 with 2 being fast, 250 being slow).
[F2 DD ?] What is the current device speed?
.....[F2 DD 2] Device is set to speed setting 2. If reply is 0, then the firmware default value (which depends on the sample holder) is being used.

13. Reference Cuvette (TC 225 only)

[R1 ...]

To control the temperature of the reference cuvette of a Dual Temperature Controller, use any commands in classes 3-8, substituting R1 for F1. There are no corresponding [R1 ...] commands for classes 9 – 11.

If you wish to ramp the temperature of the reference and sample cuvettes together, please note the linking command [F1 TL +] in command class 11.