

8 7 6 5 4 3 2

D

D

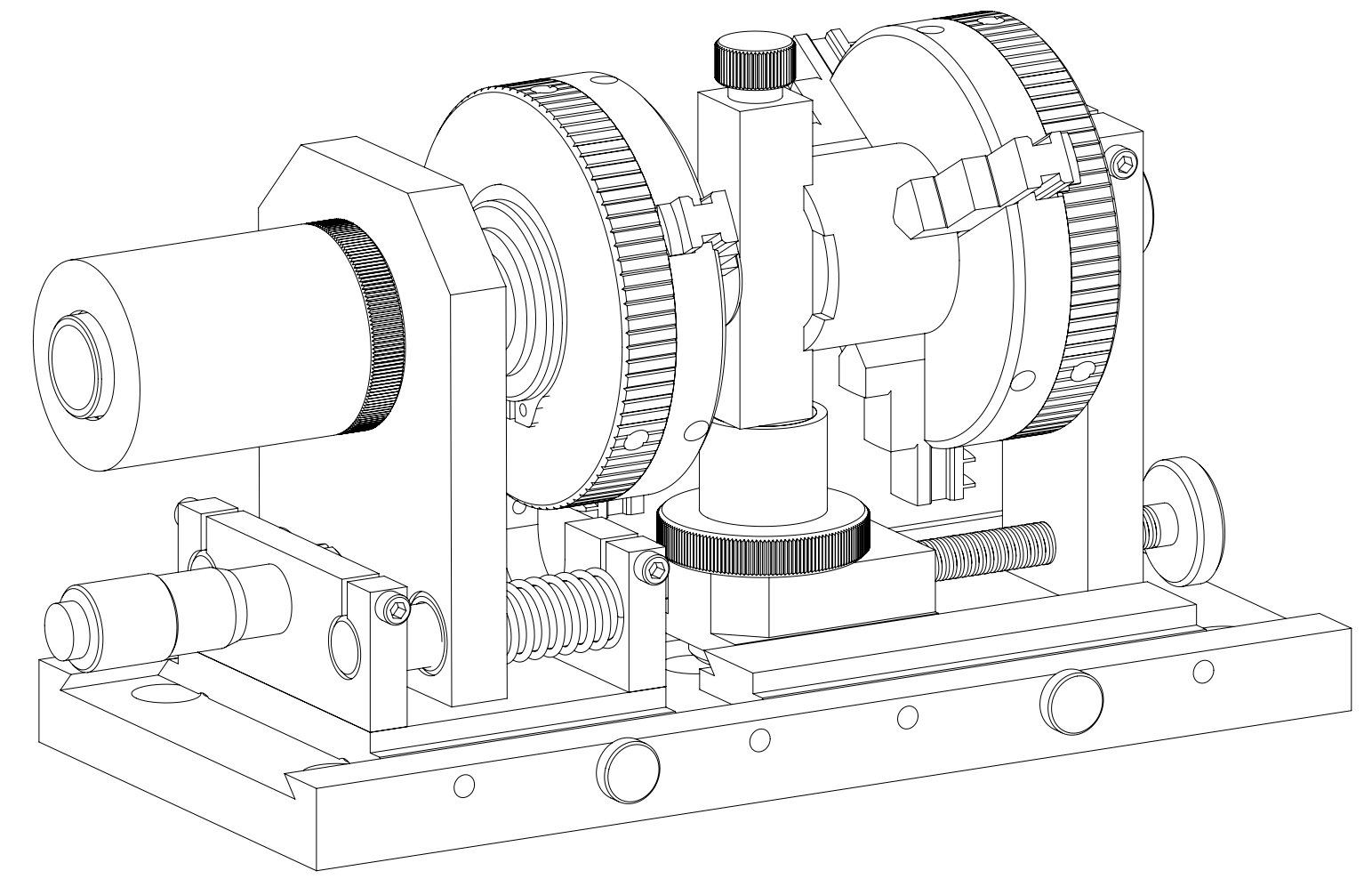
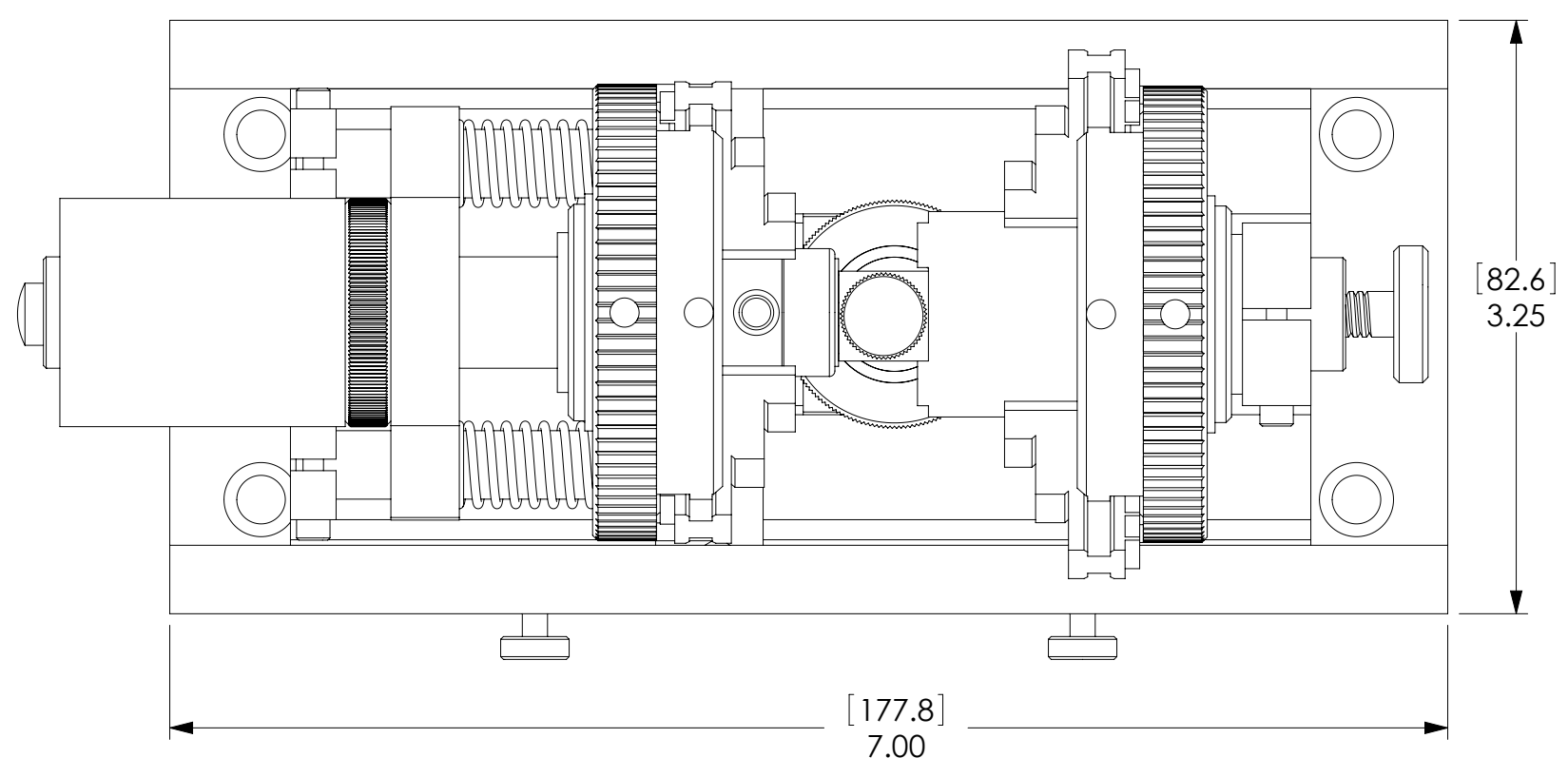

C

C

B

B

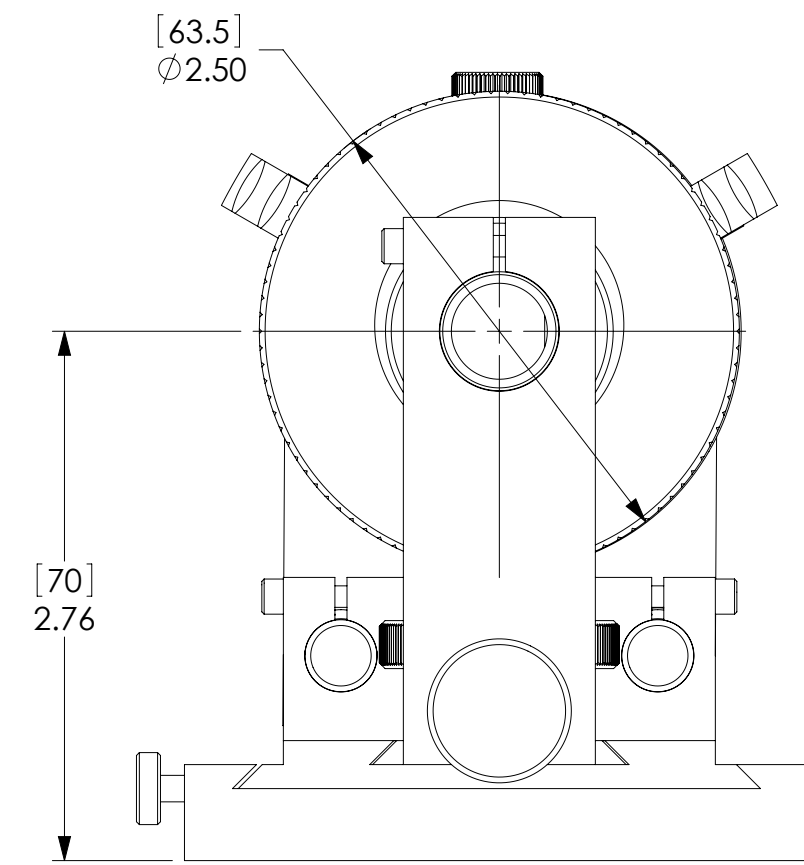
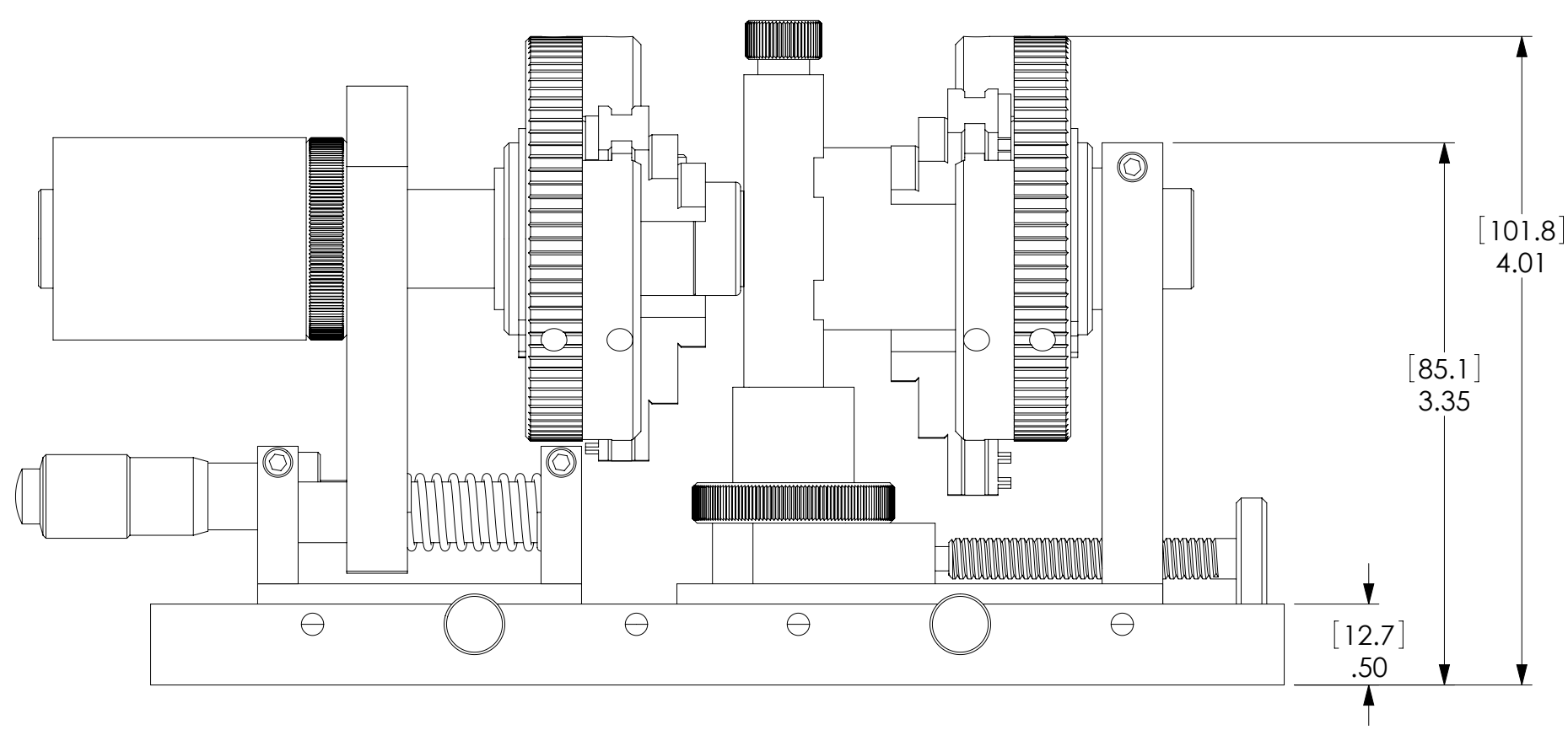

A

A

8 7 6 5 4 3 2 1

THIS DOCUMENT CONTAINS PROPRIETARY INFORMATION AND MAY NOT BE REPRODUCED OR DISCLOSED IN WHOLE OR IN PART WITHOUT WRITTEN AUTHORIZATION FROM QUANTUM NORTHWEST		QUANTUM NORTHWEST SPOKANE WASHINGTON	
DIMENSIONS ARE IN INCHES UNLESS OTHERWISE NOTED TOLERANCES ARE: DECIMALS ANGLES .XX = ± .02 X° = ± 1° .XXX = ± .003		APPROVALS DRAWN SCH ENG MFG	DATE 012100
THIRD ANGLE		SCALE: 1:1 DO NOT SCALE OFF DRAWING	SIZE DWG NO. REV. C 24317 2
		SH C:\CAD FILES*- \24317	SHEET 1 OF 1