

THIS DOCUMENT CONTAINS PROPRIETARY INFORMATION AND MAY NOT BE REPRODUCED OR DISCLOSED IN WHOLE OR IN PART WITHOUT WRITTEN AUTHORIZATION FROM QUANTUM NORTHWEST		QUANTUM NORTHWEST SPOKANE WASHINGTON	
DIMENSIONS ARE IN INCHES UNLESS OTHERWISE NOTED TOLERANCES ARE: DECIMALS ANGLES .XX = ± .02 X° = ± 1° .XXX = ± .003		APPROVALS DRAWN SCH DATE 102607 ENG MFG	FLASH 300, PMT ACCESSORY SIZE C DWG NO. 25734 REV. 1
THIRD ANGLE	SCALE: 1:1 DO NOT SCALE OFF DRAWING	SH C:\CAD FILES*- \25734	SHEET 1 OF 2

8 7 6 5 4 3 2

D

C

B

A

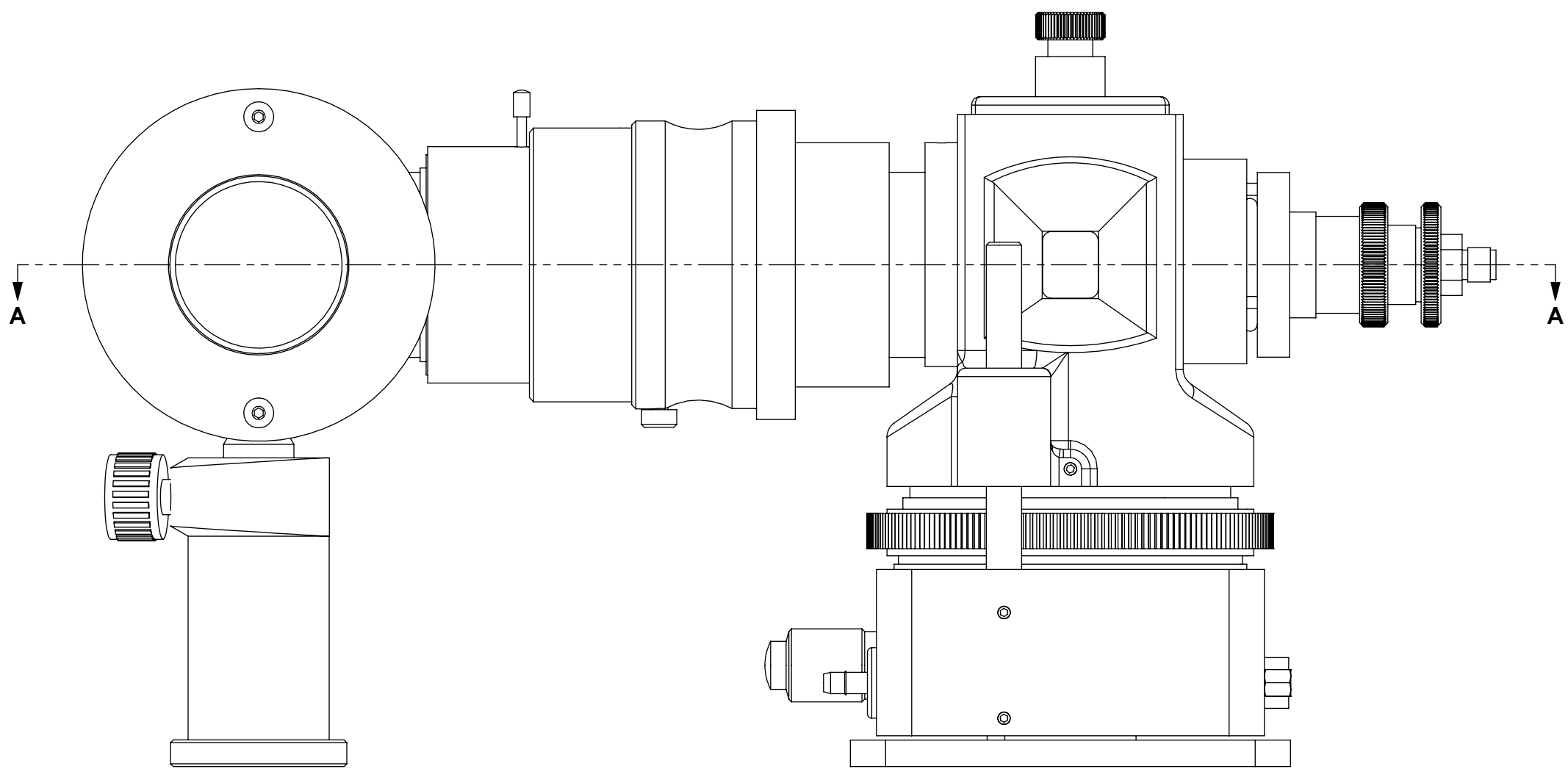
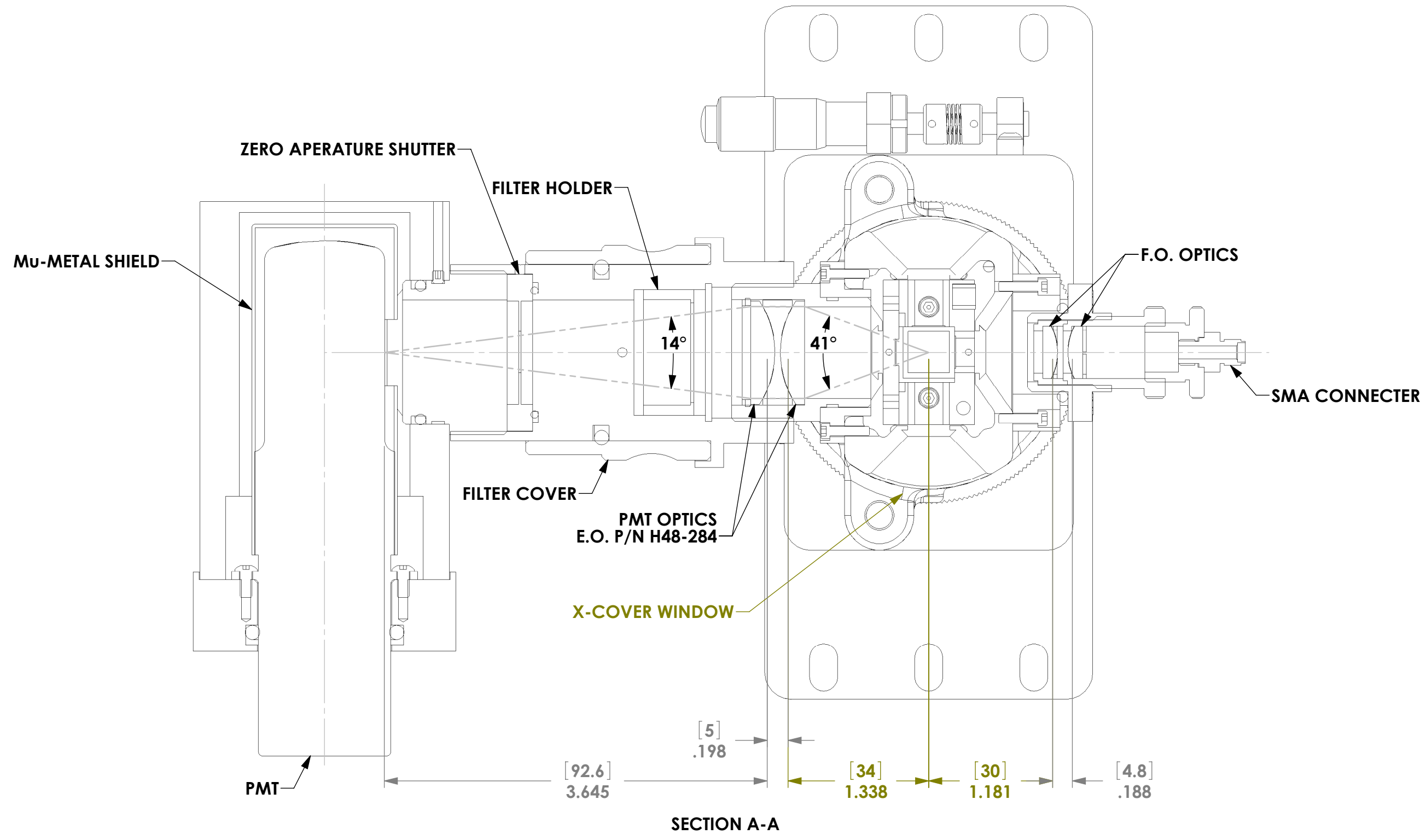

<small>THIS DOCUMENT CONTAINS PROPRIETARY INFORMATION AND MAY NOT BE REPRODUCED OR DISCLOSED IN WHOLE OR IN PART WITHOUT WRITTEN AUTHORIZATION FROM QUANTUM NORTHWEST</small>		QUANTUM NORTHWEST SPOKANE WASHINGTON	
<small>DIMENSIONS ARE IN INCHES UNLESS OTHERWISE NOTED TOLERANCES ARE:</small>		FLASH 300, PMT ACCESSORY	
<small>DECIMALS .XX = ± .02 .XXX = ± .003</small>	<small>ANGLES X° = ± 1°</small>	APPROVALS DRAWN SCH	DATE 102607
<small>THIRD ANGLE</small>		SCALE: 1:1	SIZE C DWG NO. 25734
DO NOT SCALE OFF DRAWING		SHEET 2 OF 2	

8 7 6 5 4 3 2 1